

TOP VIEW

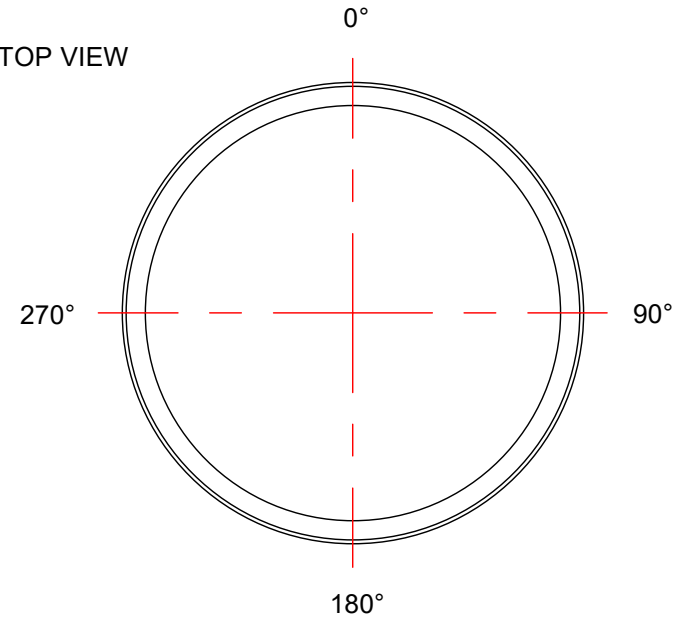

- NOTES:
1. TANK IS MANUFACTURED FROM POLYETHYLENE (HDPE) OR CROSSLINK PE (XLPE).
 2. RATING FOR STORING LIQUIDS WITH A SPECIFIC GRAVITY (DENSITY) OF 1.5SG. (1.9SG OR 2.2SG ALSO AVAILABLE)
 3. ALL TANK DIMENSIONS ARE SUBJECT TO A +/-3% TOLERANCE.
 4. ALL EXTERNAL PIPING AND ACCESSORIES MUST BE FULLY SUPPORTED AND FLEXIBLE TO AVOID STRESSING THE TANK.
 5. FITTING GASKETS AVAILABLE IN EPDM OR VITON.
 6. TANK MUST BE PROPERLY VENTED TO PREVENT PRESSURE OR VACUUM FROM DEVELOPING AS THE TANK IS FILLING OR EMPTYING.

LID TOP VIEW

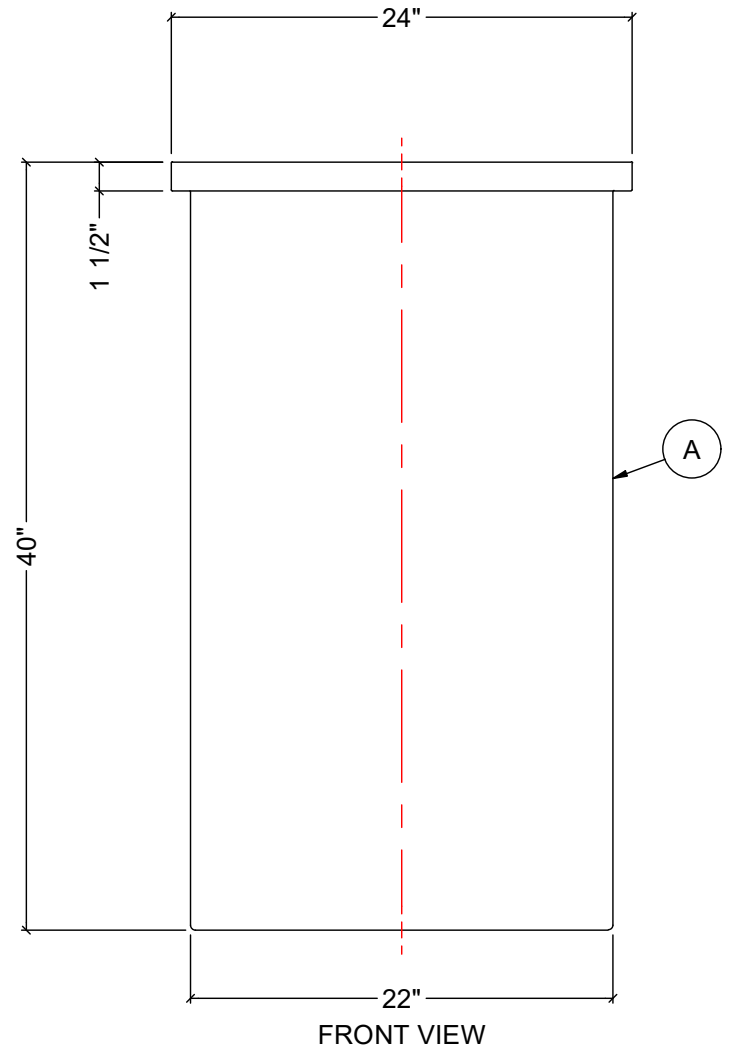
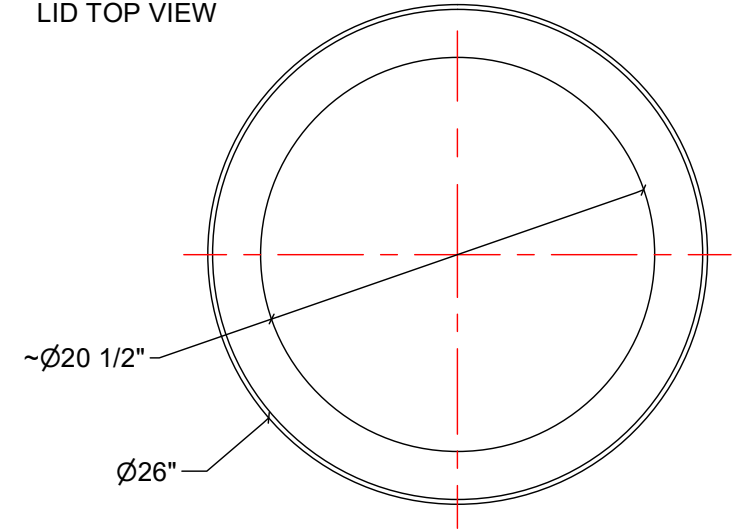

FRONT VIEW

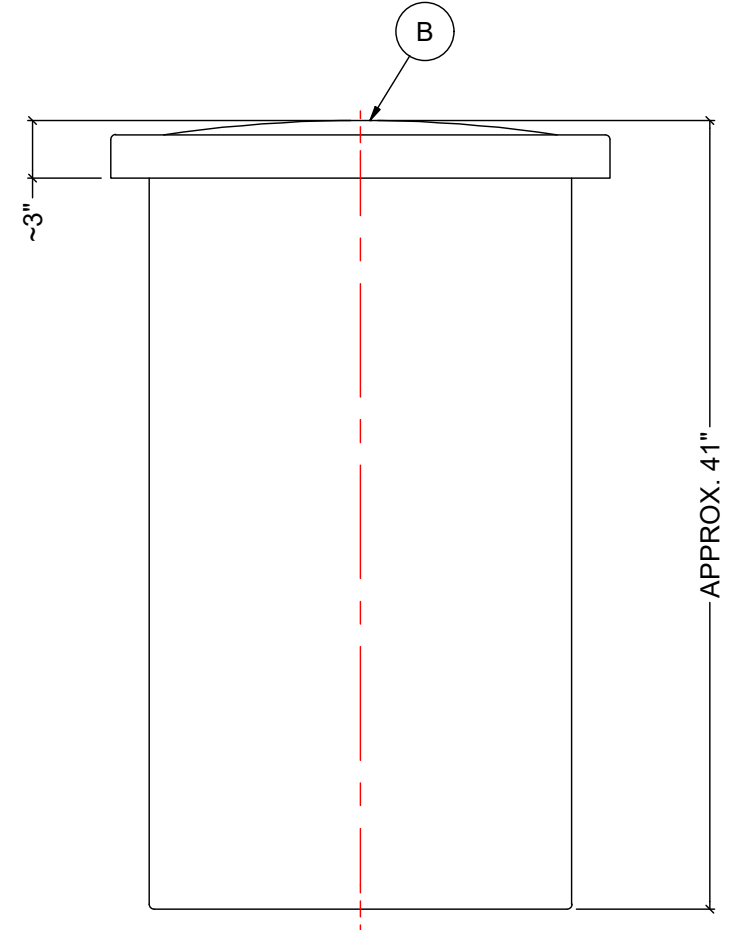

SIDE VIEW WITH LID

MATERIALS LIST		
ITEMS	DESCRIPTION	NOTES
A	OT-50 OPEN TOP TANK	
B	LID FOR OT-50	

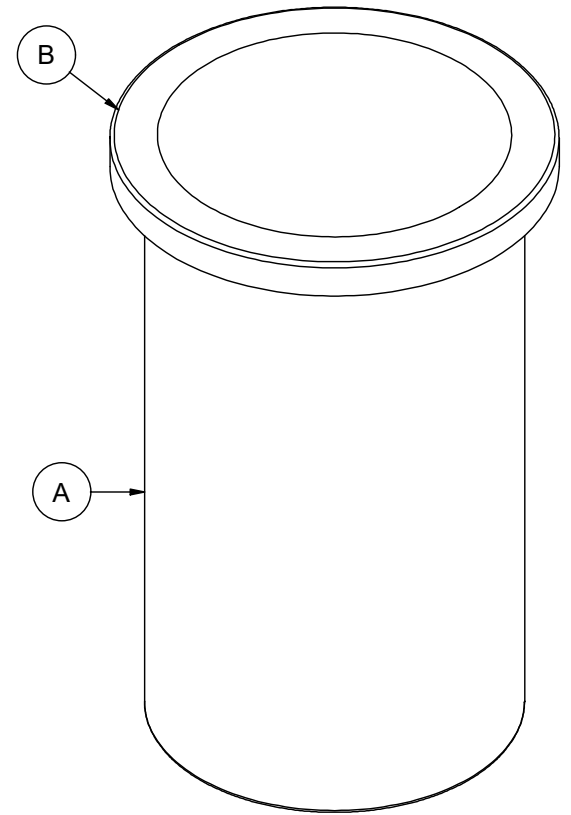

REV	DATE	DESCRIPTION	BY	APPD	REVD
1	APR-11-23	CHGD LID SHAPE	WM		

CUSTOMER

TITLE: 50 IG OPEN TOP TANK

ACO JOB NO:

PURCHASE ORDER NO:

PURCHASER'S EQUIP. NO:

THIS DRAWING IS THE PROPERTY OF ROTOPLAST INC. AND SHALL NOT BE COPIED OR TRANSFERRED WITHOUT THE WRITTEN CONSENT OF ROTOPLAST INC.

ENGINEERS SEAL

ACO CONTAINER SYSTEMS
DIVISION OF ROTOPLAST INC.

PICKERING - ONTARIO - CANADA

ACO CONTAINER SYSTEMS
DIVISION OF ROTOPLAST INC.
794 MCKAY RD.
PICKERING, ONTARIO, CANADA
TEL. 905-683-8222
FAX 905-683-2969

DESIGNED	WM
DRAWN	
CHECKED	
APPROVED	
SCALE	N.T.S.
DATE	03-03-16

DWG No: OT-50-L REV 1