

TOP VIEW

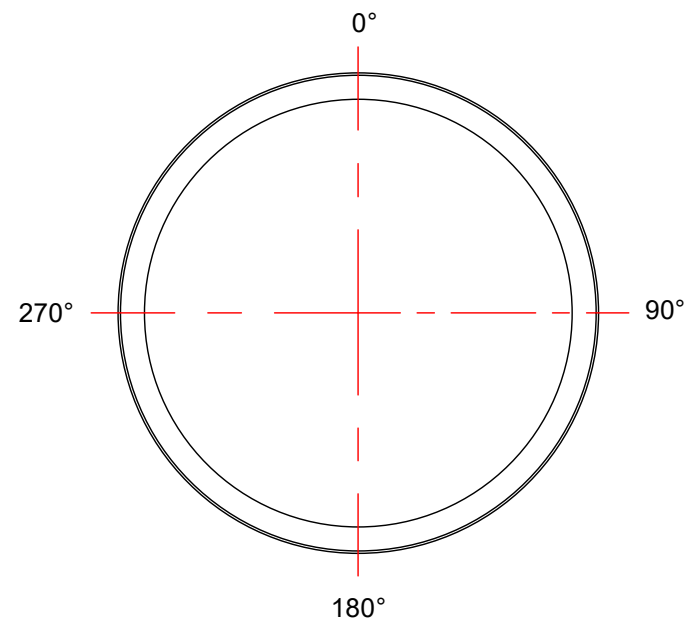

NOTES:

1. TANK IS MANUFACTURED FROM POLYETHYLENE (HDPE).
2. RATING FOR STORING LIQUIDS WITH A SPECIFIC GRAVITY (DENSITY) OF 1.5SG. (1.9SG ALSO AVAILABLE)
3. ALL TANK DIMENSIONS ARE SUBJECT TO A +/-3% TOLERANCE.
4. ALL EXTERNAL PIPING AND ACCESSORIES MUST BE FULLY SUPPORTED AND FLEXIBLE TO AVOID STRESSING THE TANK.
5. FITTING GASKETS AVAILABLE IN EPDM OR VITON.
6. TANK MUST BE PROPERLY VENTED TO PREVENT PRESSURE OR VACUUM FROM DEVELOPING AS THE TANK IS FILLING OR EMPTYING.

LID TOP VIEW

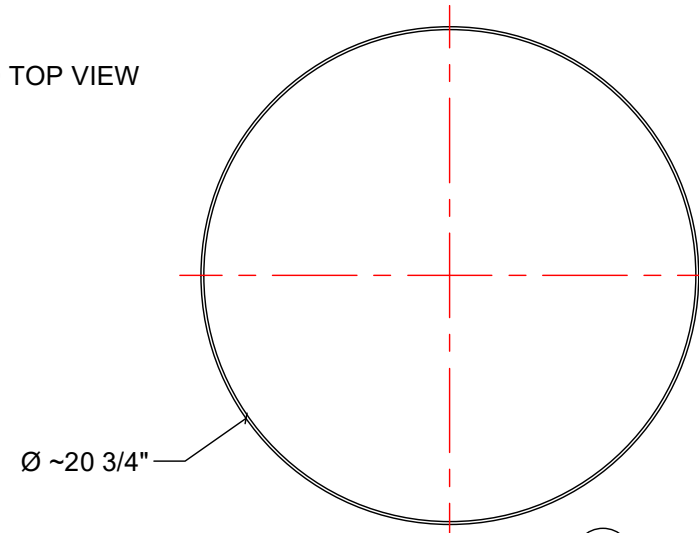

MATERIALS LIST			
ITEMS	PART#	DESCRIPTION	NOTES
A	OT-30	30 IG / 36 USG / 136L OPEN TOP TANK	
B	OT-30-L	LID FOR OT-30	

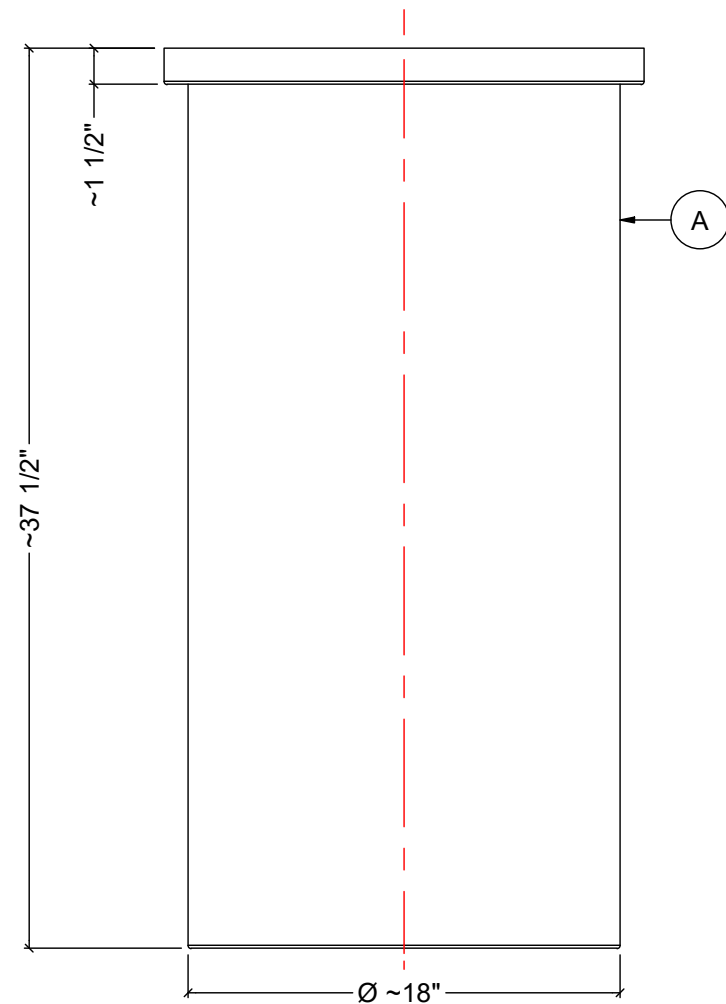
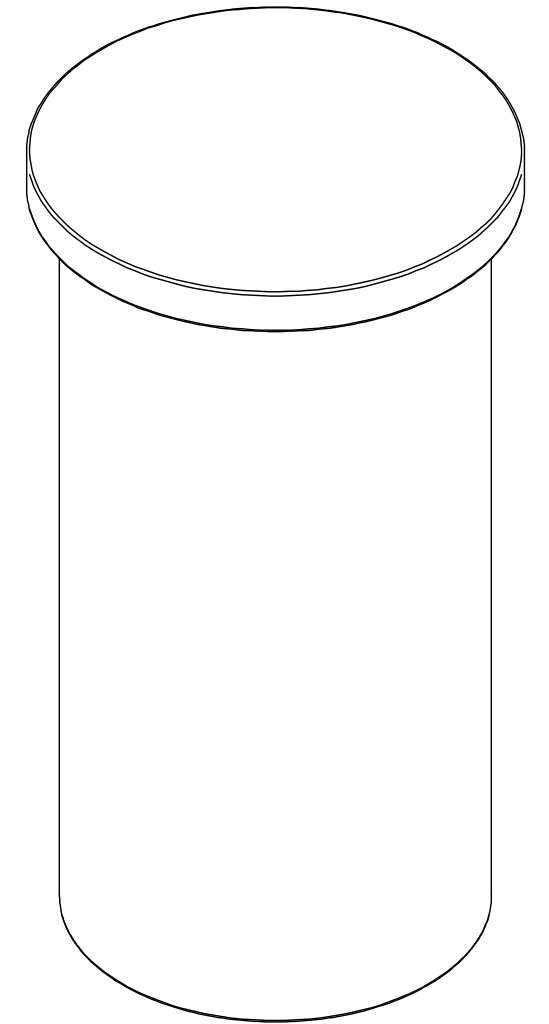

FRONT VIEW

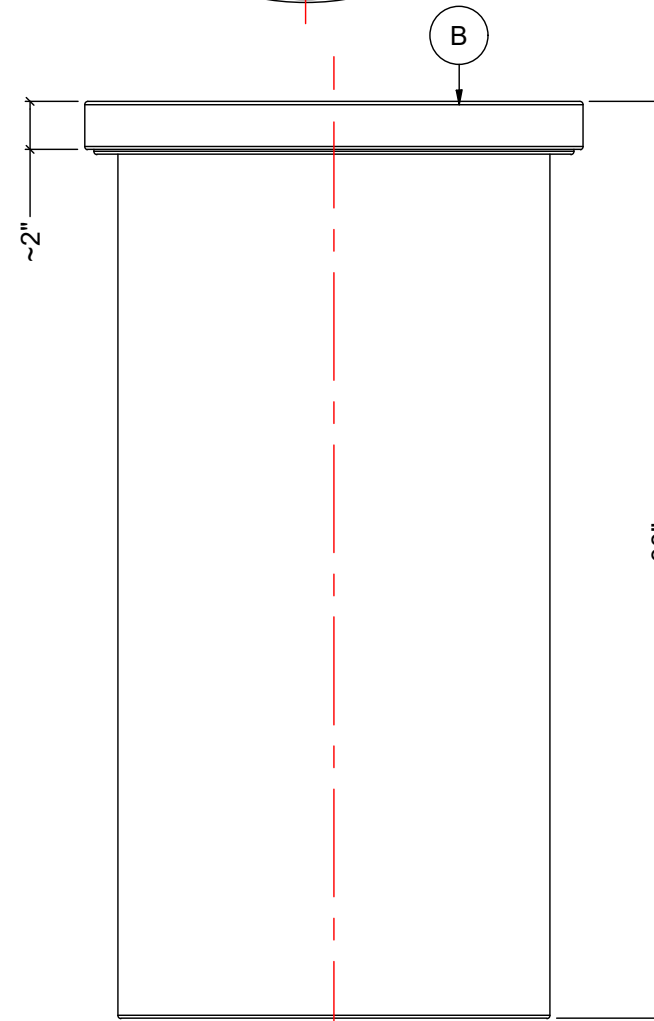

SIDE VIEW w/ LID

REV	DATE	DESCRIPTION	BY	APPD	REVD
REVISIONS					
CUSTOMER					
TITLE			ACO JOB NO:		
30 IG / 36USG / 136 L OPEN TOP TANK w/ LID			PO#:		
			EQUIP. NO:		
THIS DRAWING IS THE PROPERTY OF ROTOPLAST INC. AND SHALL NOT BE COPIED OR TRANSFERRED WITHOUT THE WRITTEN CONSENT OF ROTOPLAST INC.			 ACO CONTAINER SYSTEMS <i>A division of Rotoplast Inc.</i>		
		CHECKED			
		APPROVED			
		SCALE			N.T.S.
		DATE			12-14-2023
DWG No		OT-30-L-2024			REV