

TOP VIEW

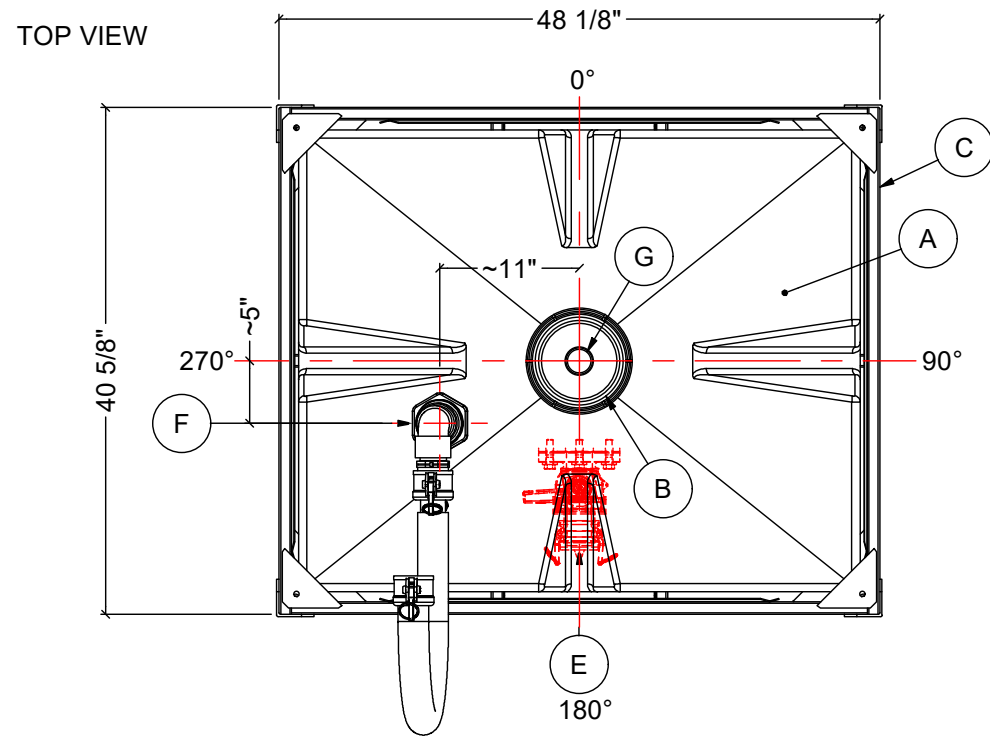

- NOTES:
 1. TANK IS AN ACO MODEL# PTC-270.
 2. ALL DIMENSIONS ARE APPROX.
 3. SOME PARTS WILL SHIP LOOSE TO AVOID DAMAGE DURING TRANSPORT.
 4. NOT UN APPROVED FOR TRANSPORTATION OF HAZARDOUS GOODS.

MATERIALS LIST		
ITEM	DESCRIPTION	NOTES
A	PTC-270 (HDPE OR XLPE) BOTTLE	
B	6" HDPE THREADED LID WITH GASKET (EPDM OR VITON) AND TIE DOWN	
C	STEEL FRAME WITH 12" KICK PLATES AND VALVE PROTECTION GATE	
D	BLACK POLY FRAME PILLOW	
E	2" BALL VALVE (POLYPRO OR STAINLESS STEEL) WITH GASKET (EPDM OR VITON)	FNPT OR CAMLOC
F	2" DOWNLOAD ASSEMBLY WITH TRANSFER HOSE	
G	1" TWO-WAY MUSHROOM VENT ASSEMBLY	
H	STEEL STACKING SPACER FOR PTC-250 OR PTC-270 WITH 12" ELEVATION AND POWDER COAT FINISH	

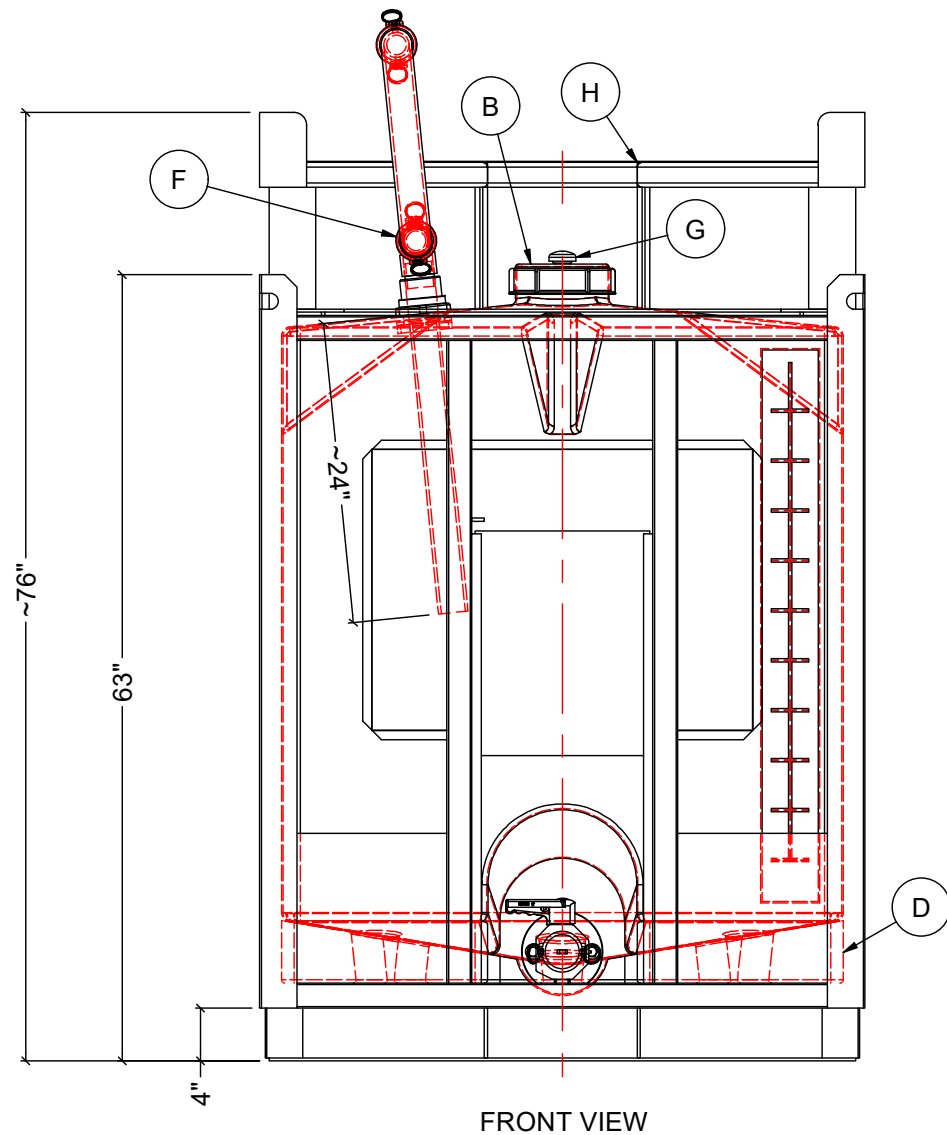

FRONT VIEW

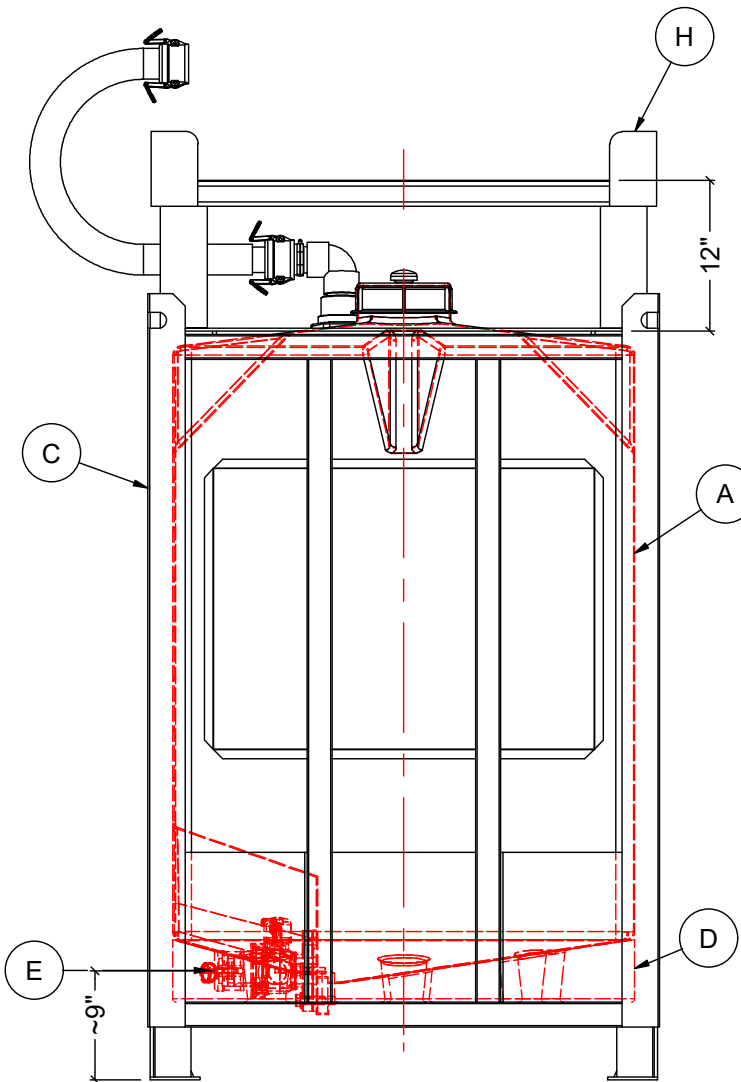

SIDE VIEW

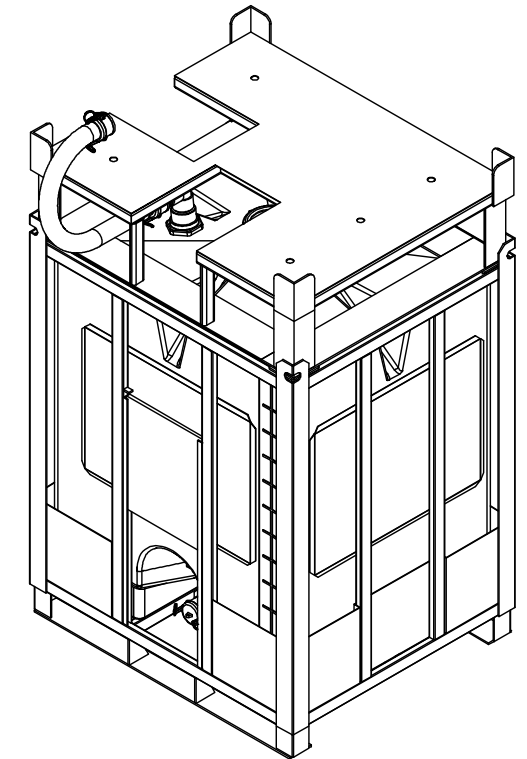

REV	DATE	DESCRIPTION	BY	APPD	REVD
REVISIONS					
CUSTOMER					
TITLE			ACO JOB NO:		
270IG (1,250L) MOTHER BIN ASSEMBLY			PO#:		
			EQUIP. NO:		
THIS DRAWING IS THE PROPERTY OF ROTOPLAST INC. AND SHALL NOT BE COPIED OR TRANSFERRED WITHOUT THE WRITTEN CONSENT OF ROTOPLAST INC.					
ENGINEERS SEAL		ACO CONTAINER SYSTEMS DIVISION OF ROTOPLAST INC. 794 MCKAY ROAD PICKERING, ONTARIO, CANADA TEL: 905-683-8222 WEB: ACOTAINERS.COM		DESIGNED	WM
				DRAWN	
				CHECKED	
				APPROVED	
				SCALE	N.T.S.
				DATE	NOV-13-2024
DWG No					REV
MOBI-270					0