

TOP VIEW

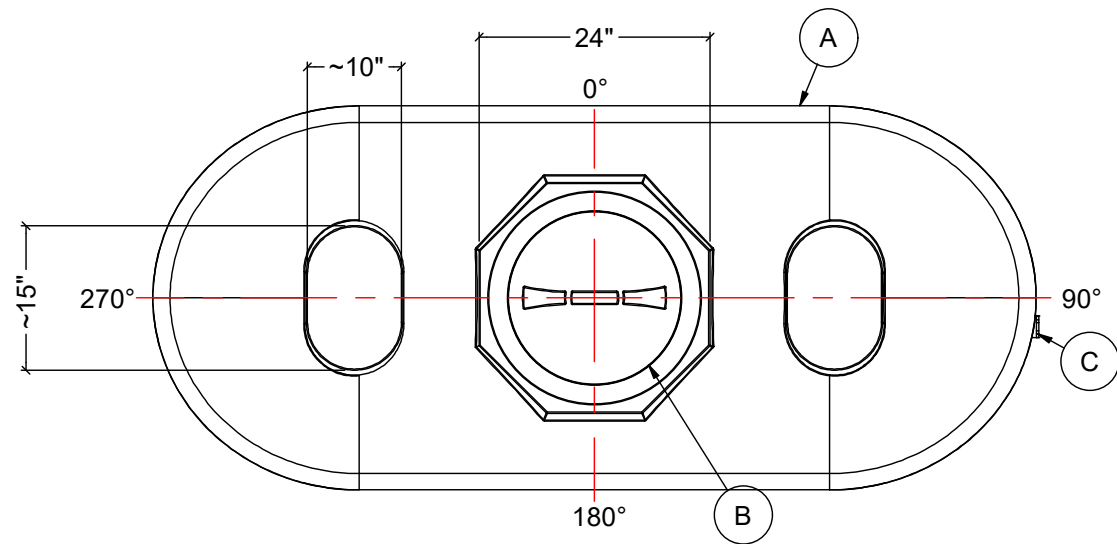

NOTES:

1. TANK IS MANUFACTURED FROM PE.
2. ALL TANK DIMENSIONS ARE SUBJECT TO A +/-3% TOLERANCE.
3. ALL EXTERNAL PIPING AND ACCESSORIES MUST BE FULLY SUPPORTED TO AVOID STRESSING THE TANK.
4. ALL FITTING GASKETS ARE EPDM.
5. FLEXIBLE COUPLINGS ARE REQUIRED FOR ALL EXTERNAL PIPING.
6. TANK MUST BE PROPERLY VENTED TO PREVENT PRESSURE OR VACUUM FROM DEVELOPING AS THE TANK IS FILLING OR EMPTYING.

MATERIALS LIST		
ITEMS	DESCRIPTION	NOTES
A	DT-3750 PE DOOR WAY TANK	
B	15" THREADED VENTED LID	
C	1-1/4" FNPT POLYPRO TANK ADAPTER	

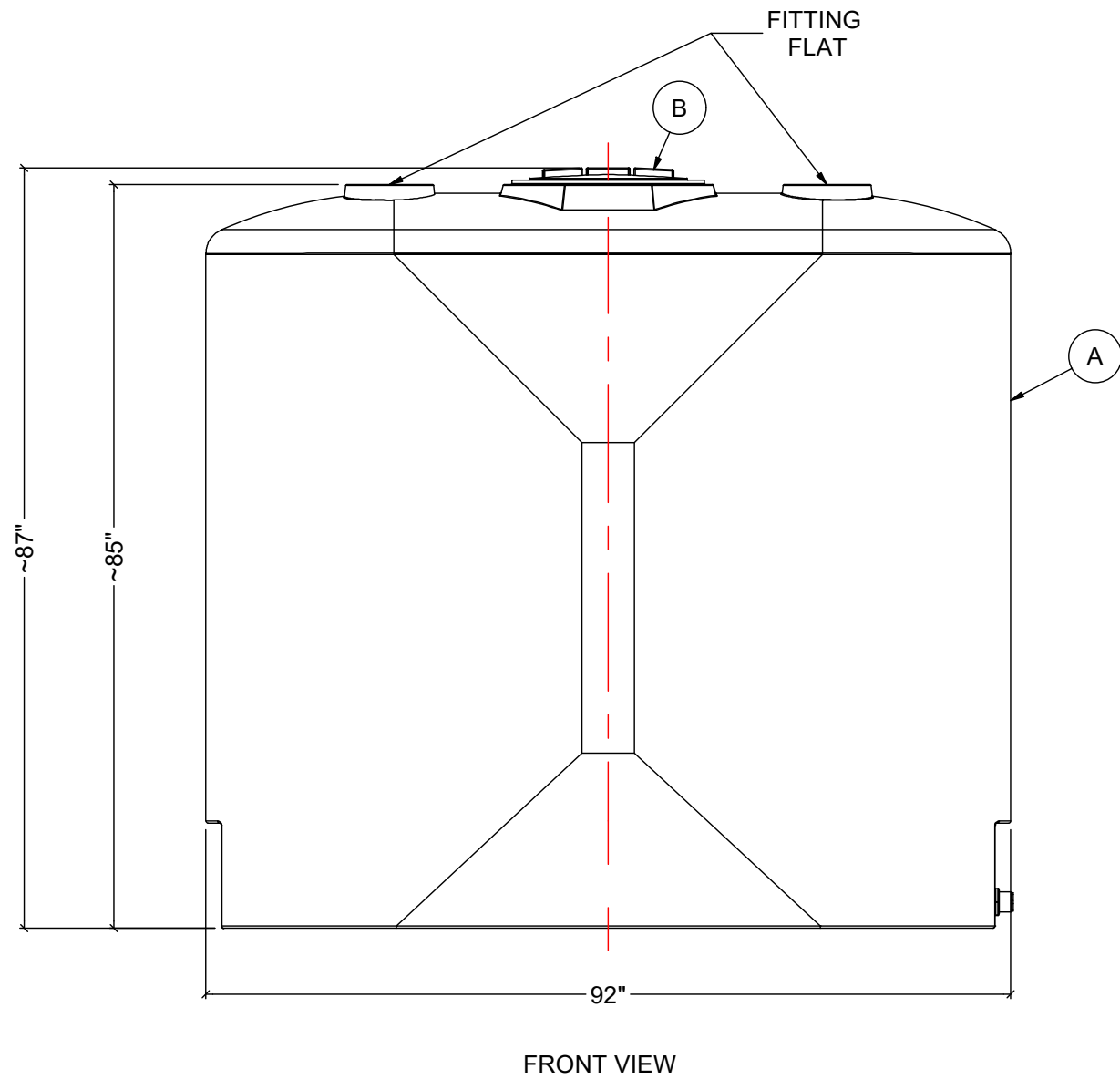

FRONT VIEW

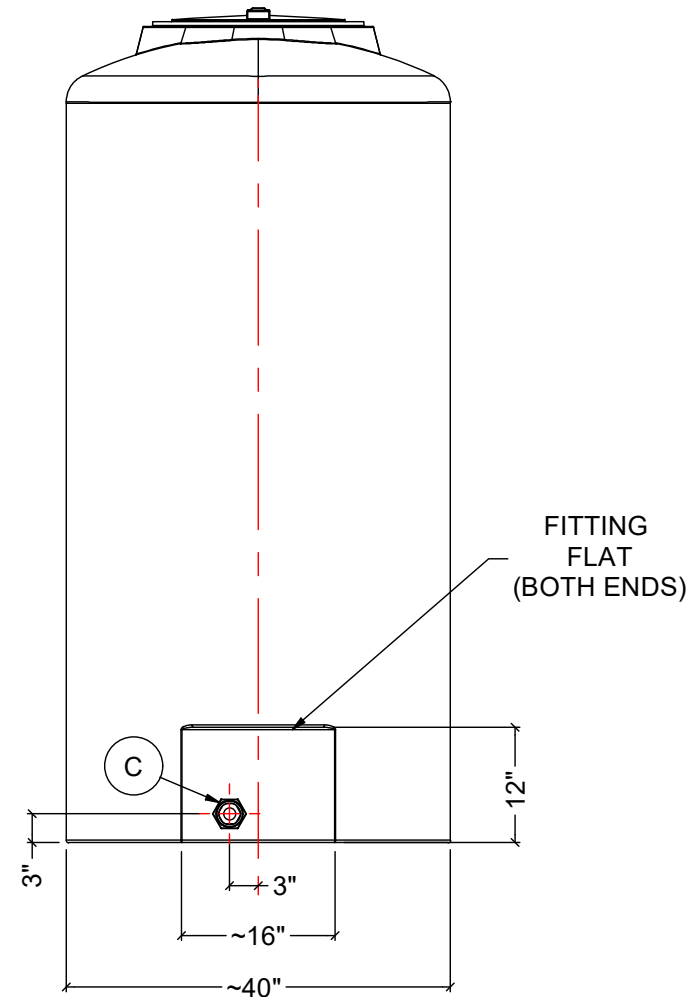

SIDE VIEW

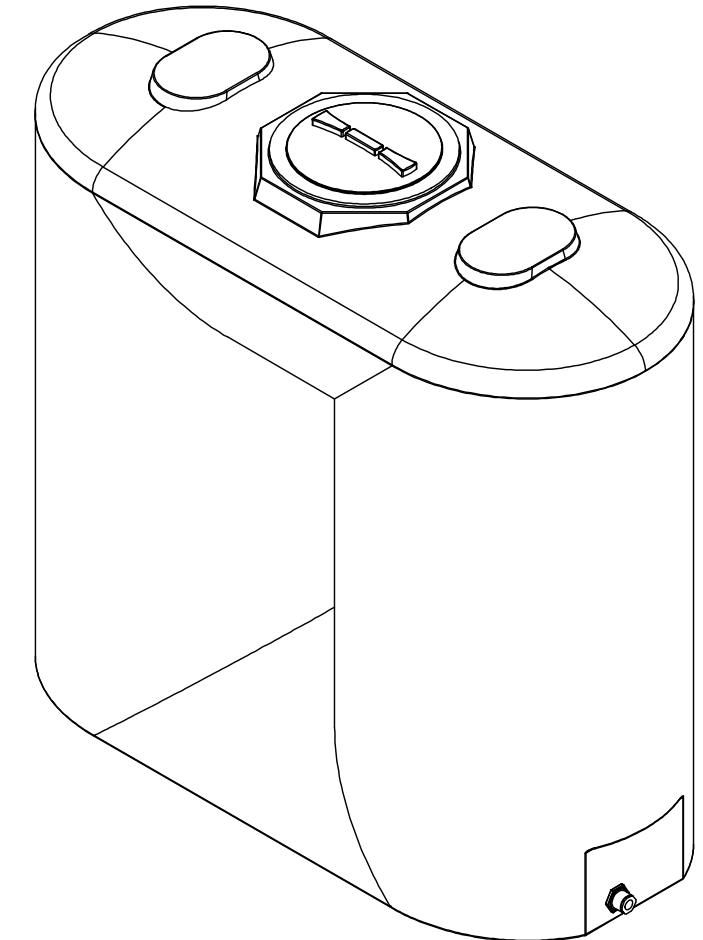

REV	DATE	DESCRIPTION	BY	APPD	REVD
REVISIONS					
CUSTOMER					
TITLE			ACO JOB NO:		
3750 L DOOR WAY TANK			PO#:		
			EQUIP. NO:		
THIS DRAWING IS THE PROPERTY OF ROTOPLAST INC. AND SHALL NOT BE COPIED OR TRANSFERRED WITHOUT THE WRITTEN CONSENT OF ROTOPLAST INC.			 ACO CONTAINER SYSTEMS <i>A division of Rotoplast Inc.</i>		
		CHECKED			
		APPROVED			
		SCALE		N.T.S.	
		DATE		SEP-19-2024	
DWG No			DW-3750		REV 0