

TOP VIEW

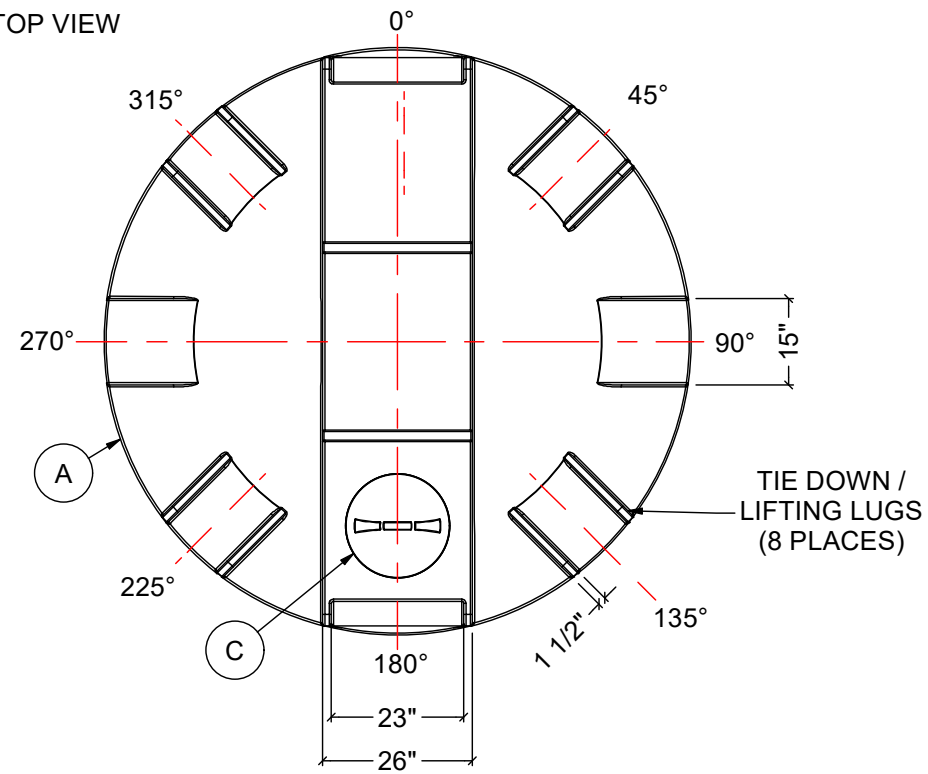

NOTES:

1. TANK IS MANUFACTURED FROM POLYETHYLENE (PE) OR CROSSLINK PE (XLPE).
2. RATING FOR STORING LIQUIDS WITH A SPECIFIC GRAVITY (DENSITY) OF 1.5SG. (1.9SG ALSO AVAILABLE)
3. ALL TANK DIMENSIONS ARE SUBJECT TO A +/-3% TOLERANCE.
4. ALL EXTERNAL PIPING AND ACCESSORIES MUST BE FULLY SUPPORTED AND FLEXIBLE TO AVOID STRESSING THE TANK.
5. FITTING GASKETS AVAILABLE IN EPDM OR VITON.
6. TANK MUST BE PROPERLY VENTED TO PREVENT PRESSURE OR VACUUM FROM DEVELOPING AS THE TANK IS FILLING OR EMPTYING.
7. STANDARD LID IS 15" NON-VENTED OR VENTED. LID ALSO AVAILABLE IN 21" VENTED OR NON-VENTED.
8. TANK IS MANUFACTURED TO ASTM-D-1998 STANDARD
9. BOTTOM OUTLET FITTING MAY ONLY BE INSTALLED ON A FITTING FLAT LOCATED AT 0°, 90°, 180° OR 270°.
10. CONTAINMENT TANK IS 1.5SG PE AS STANDARD.

MATERIALS LIST		
ITEMS	DESCRIPTION	NOTES
A	DCT-2902 PRIMARY TANK	
B	DCT-2902 CONTAINMENT TANK	
C	15" THREADED LID	

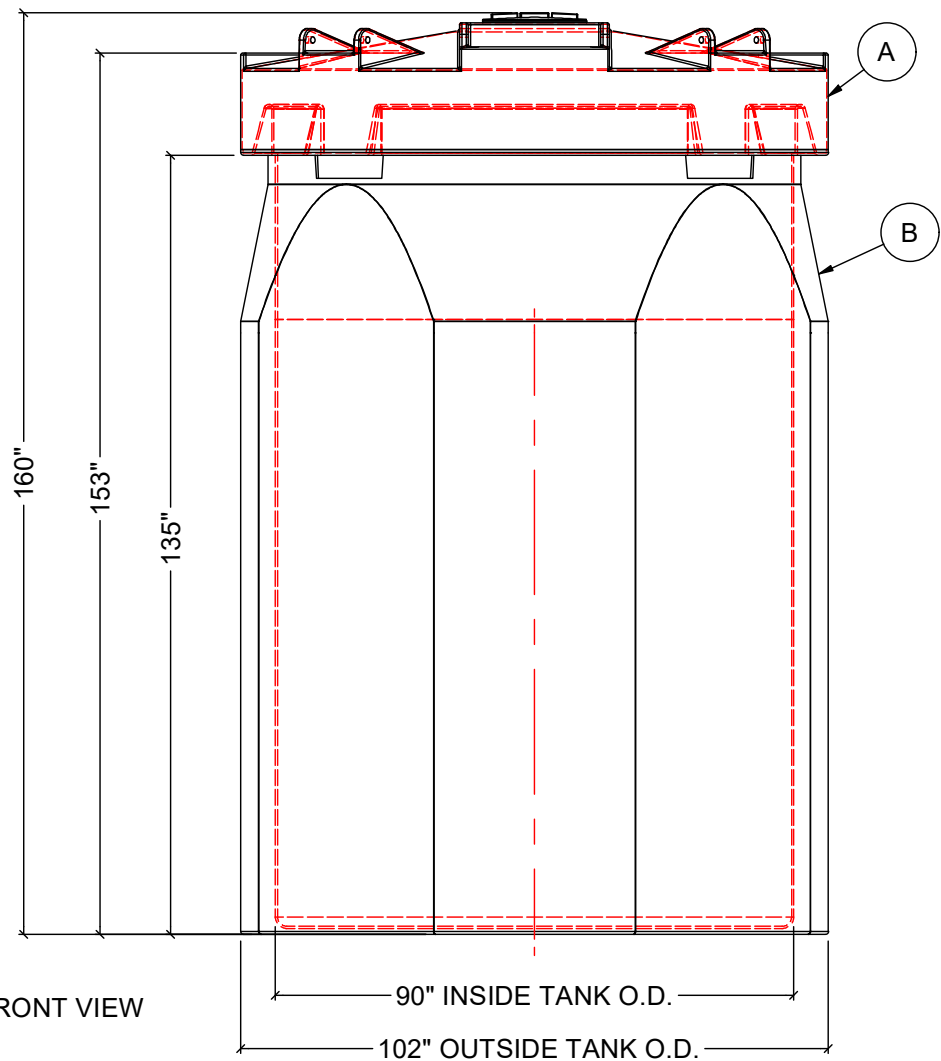
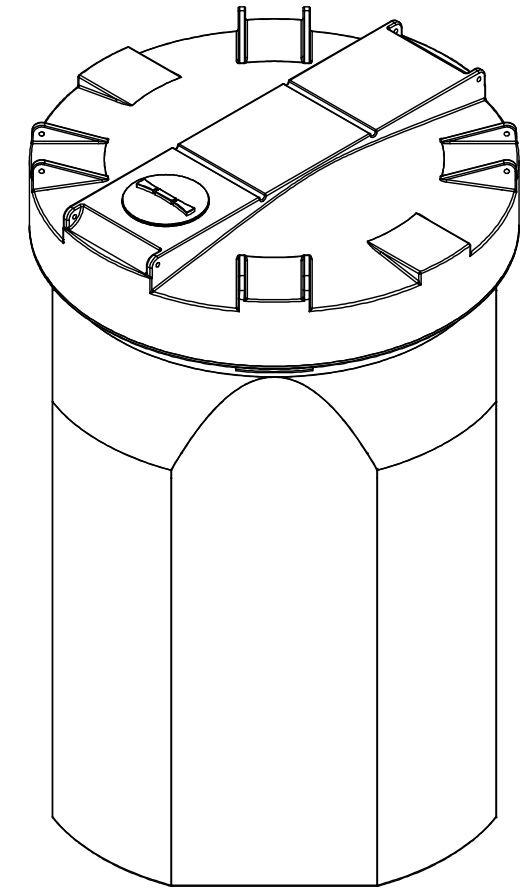

FRONT VIEW

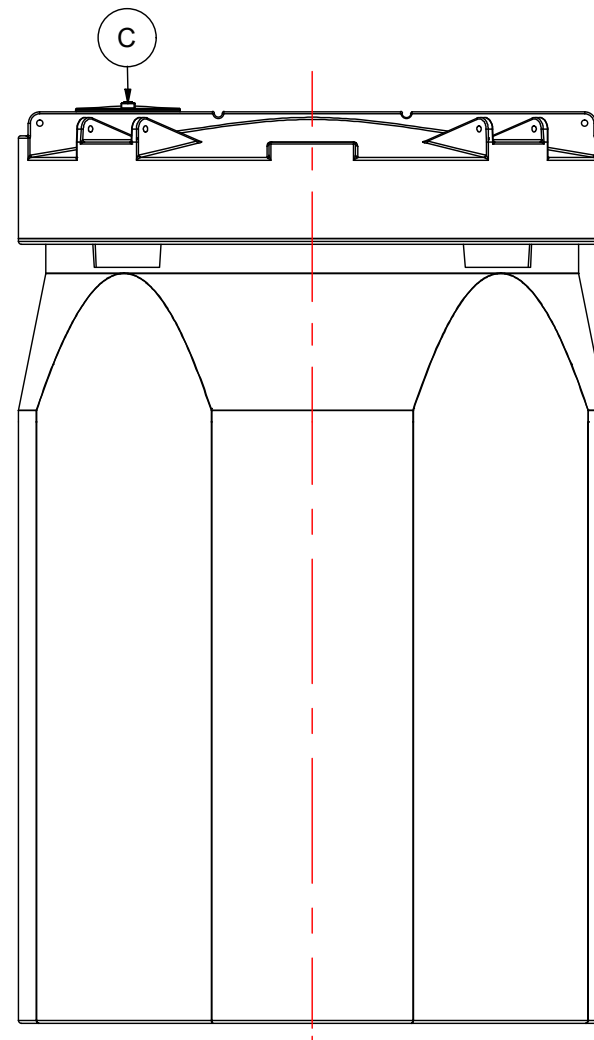

SIDE VIEW

REV	DATE	DESCRIPTION	BY	APPD	REVD
REVISIONS					
CUSTOMER					
TITLE		ACO JOB NO:			
2900 IG DOUBLE WALL TANK		PURCHASE ORDER NO:			
		PURCHASER'S EQUIP. NO:			
THIS DRAWING IS THE PROPERTY OF ROTOPLAST INC. AND SHALL NOT BE COPIED OR TRANSFERRED WITHOUT THE WRITTEN CONSENT OF ROTOPLAST INC.					
ENGINEERS SEAL		ACO CONTAINER SYSTEMS DIVISION OF ROTOPLAST INC.			
<small>PICKERING - ONTARIO - CANADA</small>					
<small>ACO CONTAINER SYSTEMS DIVISION OF ROTOPLAST INC. 794 MCKAY RD. PICKERING, ONTARIO, CANADA TEL. 905-683-8222 FAX 905-683-2969</small>		<small>DESIGNED</small>	<small>DRAWN</small>	<small>CHECKED</small>	<small>APPROVED</small>
					WM
		<small>SCALE</small>	<small>DATE</small>	<small>N.T.S.</small>	<small>31-03-16</small>
<small>DWG No</small>		DCT-2902			<small>REV</small>
					0