

- NOTES:
1. TANK IS MANUFACTURED FROM POLYETHYLENE (PE) OR CROSSLINK PE (XLPE).
  2. RATING FOR STORING LIQUIDS WITH A SPECIFIC GRAVITY (DENSITY) OF 1.5SG. (1.9SG ALSO AVAILABLE)
  3. ALL TANK DIMENSIONS ARE SUBJECT TO A +/-3% TOLERANCE.
  4. ALL EXTERNAL PIPING AND ACCESSORIES MUST BE FULLY SUPPORTED AND FLEXIBLE TO AVOID STRESSING THE TANK.
  5. FITTING GASKETS AVAILABLE IN EPDM OR VITON.
  6. TANK MUST BE PROPERLY VENTED TO PREVENT PRESSURE OR VACUUM FROM DEVELOPING AS THE TANK IS FILLING OR EMPTYING.
  7. STANDARD LID IS 15" NON-VENTED. LID ALSO AVAILABLE IN 21" VENTED OR NON-VENTED.
  8. TANK IS MANUFACTURED TO ASTM-D-1998 STANDARD

MATERIALS LIST		
ITEMS	DESCRIPTION	NOTES
A	CT-6620 CLOSED TOP TANK	
B	15" THREADED LID	

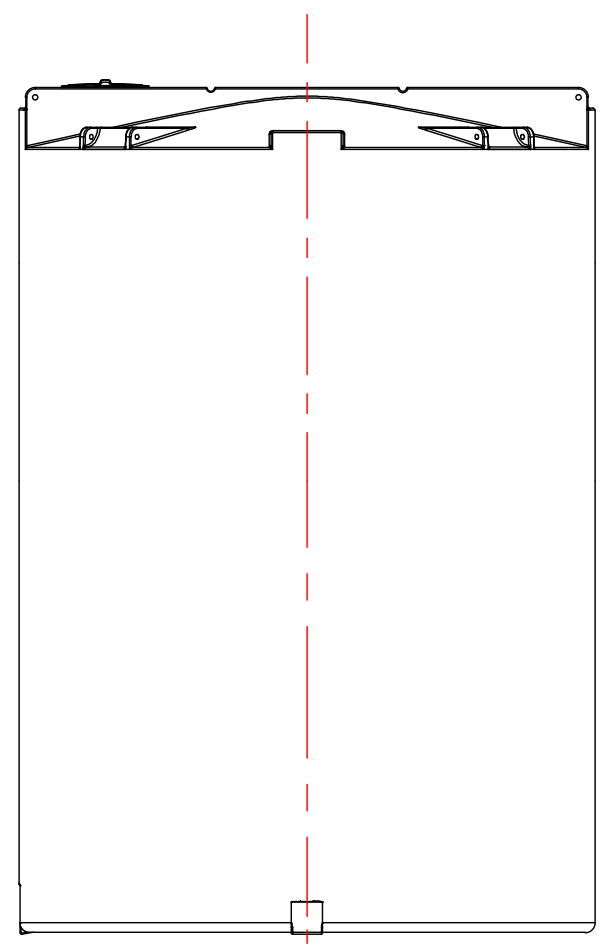
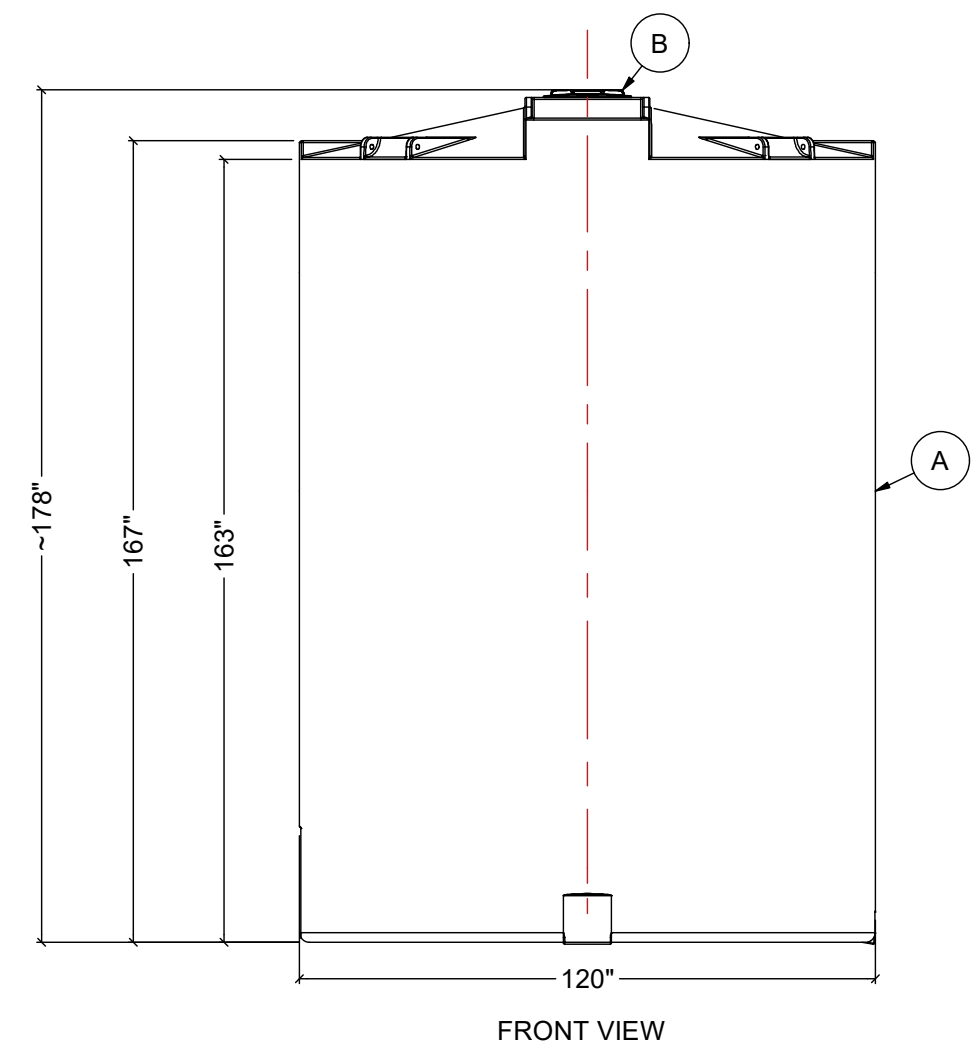
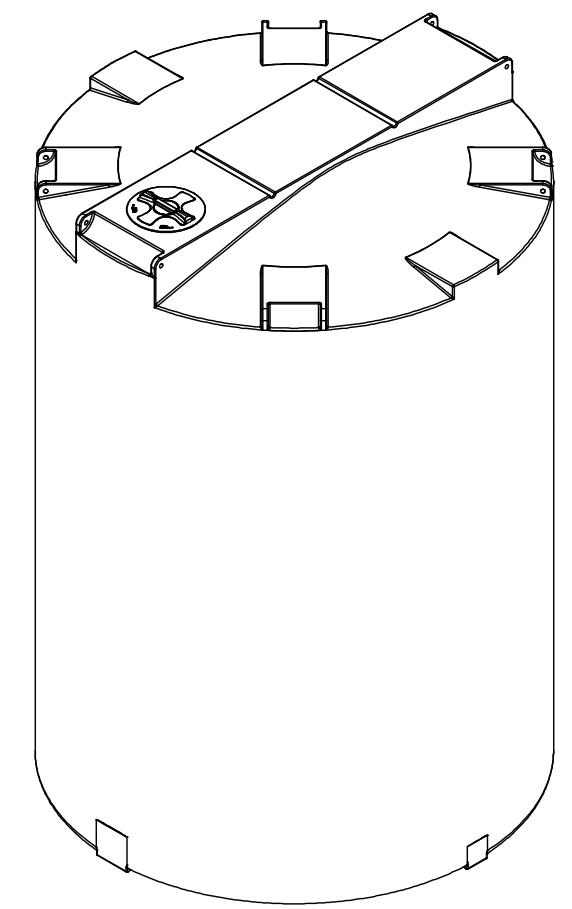

REV	DATE	DESCRIPTION	BY	APPD	REVD	
REVISIONS						
CUSTOMER						
TITLE		ACO JOB NO:				
6620 IG CLOSED TOP TANK		PURCHASE ORDER NO:				
		PURCHASER'S EQUIP. NO:				
THIS DRAWING IS THE PROPERTY OF ROTOPLAST INC. AND SHALL NOT BE COPIED OR TRANSFERRED WITHOUT THE WRITTEN CONSENT OF ROTOPLAST INC.						
ENGINEERS SEAL		<b>ACO CONTAINER SYSTEMS</b> DIVISION OF ROTOPLAST INC. <small>PICKERING - ONTARIO - CANADA</small> ACO CONTAINER SYSTEMS DIVISION OF ROTOPLAST INC. 794 MCKAY RD. PICKERING, ONTARIO, CANADA TEL. 905-683-8222 FAX 905-683-2969 <small>DWG No</small>				
		DESIGNED		WM		
		DRAWN				
		CHECKED				
		APPROVED				
		SCALE		N.T.S.		
		DATE		02-03-16		
		CT-6620			REV	0