

- NOTES:
1. TANK IS MANUFACTURED FROM POLYETHYLENE (PE) OR CROSSLINK PE (XLPE).
 2. RATED FOR STORING LIQUIDS WITH A SPECIFIC GRAVITY (DENSITY) OF 1.5SG.(1.9SG OR 2.2SG ALSO AVAILABLE)
 3. ALL TANK DIMENSIONS ARE SUBJECT TO A +/-3% TOLERANCE.
 4. ALL EXTERNAL PIPING AND ACCESSORIES MUST BE FULLY SUPPORTED AND FLEXIBLE TO AVOID STRESSING THE TANK.
 5. FITTING GASKETS AVAILABLE IN EPDM OR VITON.
 6. TANK MUST BE PROPERLY VENTED TO PREVENT PRESSURE OR VACUUM FROM DEVELOPING AS THE TANK IS FILLING OR EMPTYING.
 7. TANK IS MANUFACTURED TO ASTM-D-1998 STANDARD.

MATERIALS LIST		
ITEMS	DESCRIPTION	NOTES
A	CT-2455 CLOSED TOP TANK	
B	16" LID WITH LOCKING STRAP	

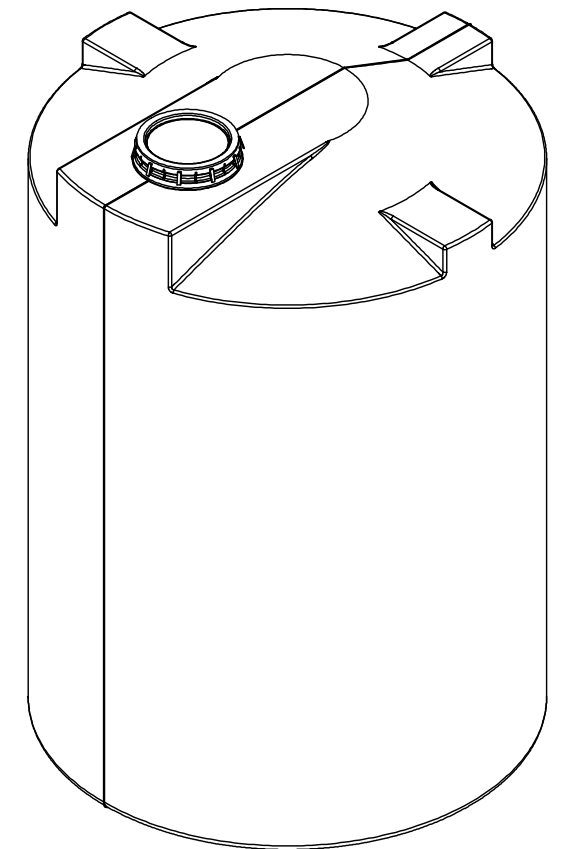

REV	DATE	DESCRIPTION	BY	APPD	REVD
1	NOV-01-18	ADDED PARTING LINE	WM		

REVISIONS	
CUSTOMER	
TITLE	ACO JOB NO:
2,450 IG CLOSED TOP TANK	PURCHASE ORDER NO:
	PURCHASER'S EQUIP. NO:

THIS DRAWING IS THE PROPERTY OF ROTOPLAST INC. AND SHALL NOT BE COPIED OR TRANSFERRED WITHOUT THE WRITTEN CONSENT OF ROTOPLAST INC.	 <p>ACO CONTAINER SYSTEMS A division of Rotoplast Inc.</p>	DESIGNED	
		DRAWN	WM
ENGINEERS SEAL	ACO CONTAINER SYSTEMS DIVISION OF ROTOPLAST INC. 794 MCKAY ROAD PICKERING, ONTARIO, CANADA TEL: 905-683-8222 WEB: ACOTAINERS.COM	CHECKED	
		APPROVED	
		SCALE	N.T.S.
		DATE	02-03-2016
DWG No	CT-2455	REV	1