

PLAN VIEW

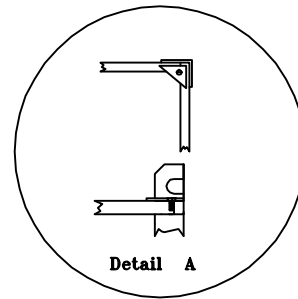

NOZZLE SCHEDULE			
ITEM	DESCRIPTIPON	SIZE"	REMARKS
A	MANHOLE	6	HDPE
B	STACKING BRACKET	--	
C	STEEL FRAME	3 X 3	ANGLE 3/16 THICK
D	STEEL SUPPORT PLATE	--	INNER
E	STORAGE CONTAINER	--	LLDPE
F	STEEL SUPPORT PLATE	--	OUTER
G	SIGHT WINDOW (LEVEL)	--	CUT OUT OF PANEL

** ALL DIMENSIONS ARE APPROXIMATE **

BOTTLE IS MADE FROM XLPE RESIN
 GASKETS ARE MADE FROM E.P.D.M.
 UNIT IS RATED FOR 2.0 SPECIFIC GRAVITY

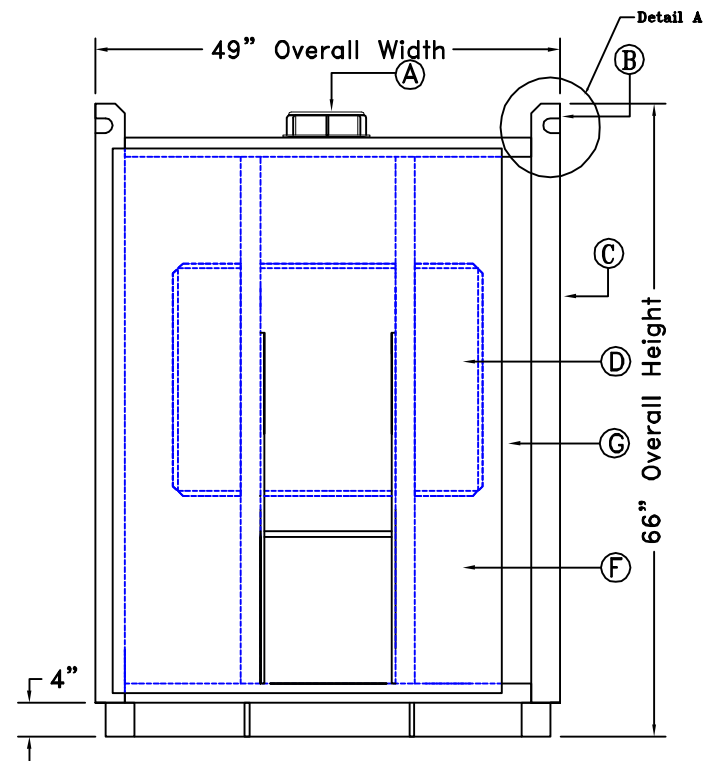

FRONT VIEW

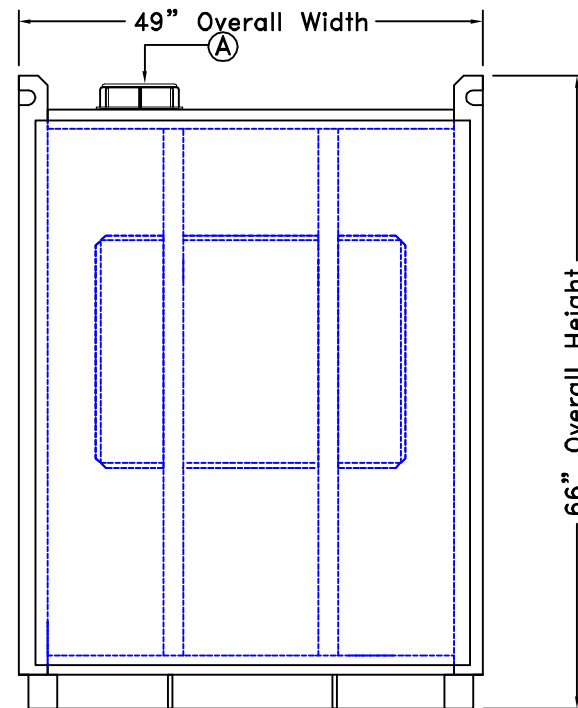

SIDE VIEW

REV	DATE	DESCRIPTION	BY	APPD	REVD
REVISIONS					

CUSTOMER	
TITLE	ACO JOB NO: --
FULLY ENCLOSED PTC-330TDA	PURCHASE ORDER NO: --
	PURCHASER'S EQUIP. NO:--

THIS DRAWING IS THE PROPERTY OF ROTOPLAST INC.
 AND SHALL NOT BE COPIED OR TRANSFERRED WITHOUT THE
 WRITTEN CONSENT OF ROTOPLAST INC.

ENGINEERS SEAL	ACO CONTAINER SYSTEMS DIVISION OF ROTOPLAST INC.	
	PICKERING - ONTARIO - CANADA	
	ACO CONTAINER SYSTEMS LTD. DIVISION OF ROTOPLAST INC. 794 MCKAY RD. PICKERING, ONTARIO, CANADA TEL. 905-683-8222 FAX 905-683-2969	DESIGNED - DRAWN - CHECKED - APPROVED - SCALE N.T.S. DATE -
DWG No	PTC-330-FE	REV 0