

TOP VIEW

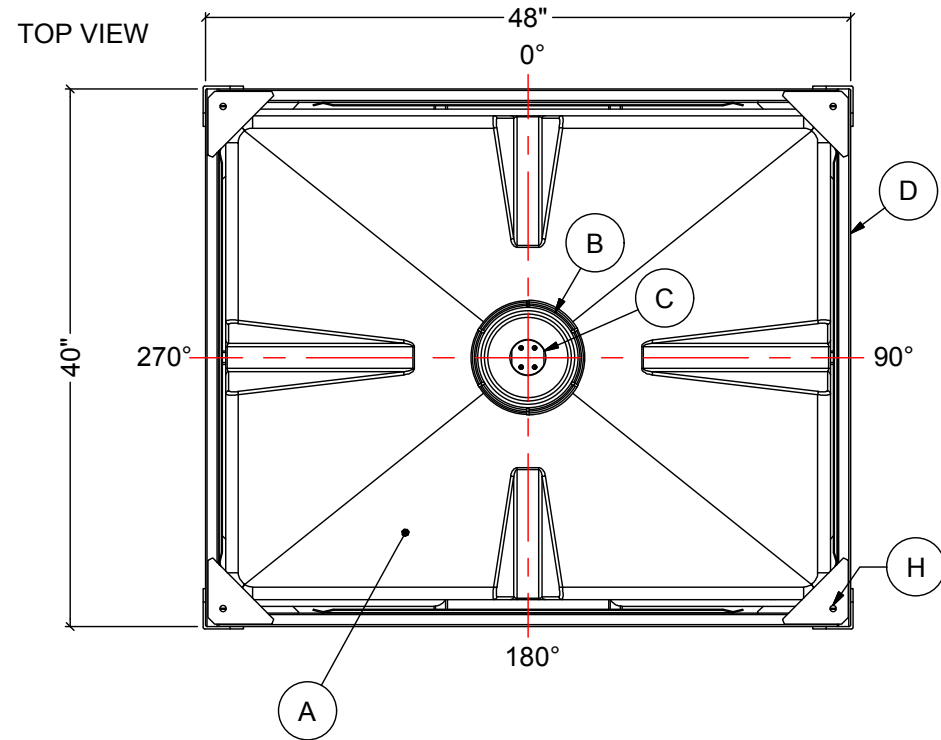

NOTES:

1. CAPACITY: 200 IMP GAL (910 L)
2. TARE WEIGHT: 547 LBS (248 KG)
3. PRIMARY MARKINGS: U.N. 31HA1/Y/

STACKING BRACKET DETAIL (H)

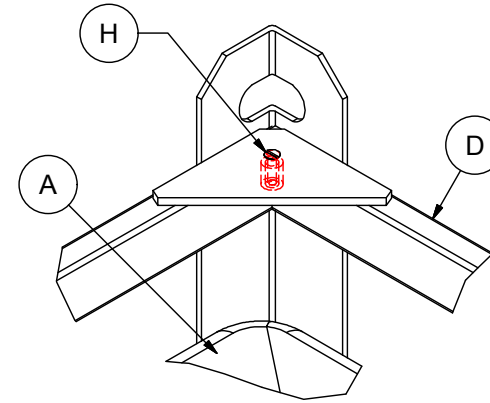

MATERIALS LIST		
ITEM	DESCRIPTION	NOTES
A	PTC-200 HDPE BOTTLE	
B	6" THREADED LID	
C	2" COMBI-VENT - VACUUM AND PRESSURE RELIEF (OPTIONAL)	IN LID
D	STEEL FRAME WITH 12" KICKPLATES AND VALVE PROTECTION GATE	
E	2IN POLYPRO BALL VALVE-CAM LOCK FITTING	
F	VALVE MOUNTING HARDWARE KIT	
G	BLACK POLY FRAME PILLOW	
H	FRAME CORNER STACKING BRACKET WITH SCREW	4 PLACES
J	UN FRAME TAG	

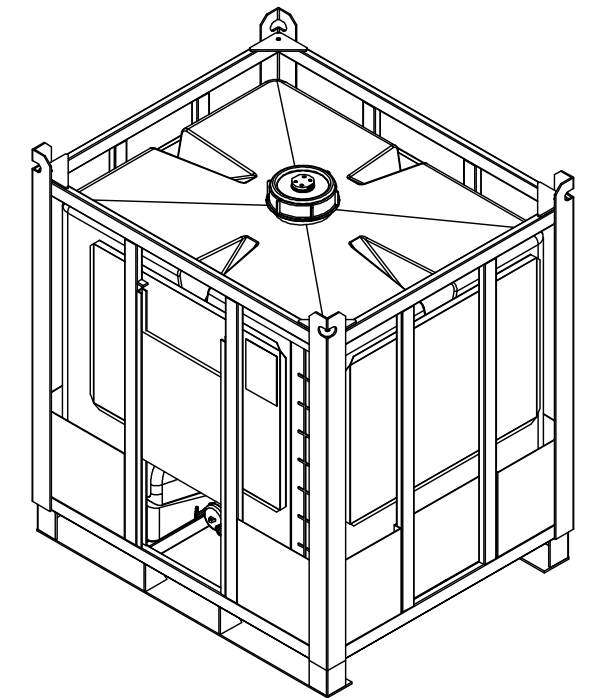

INNER SUPPORT PLATE

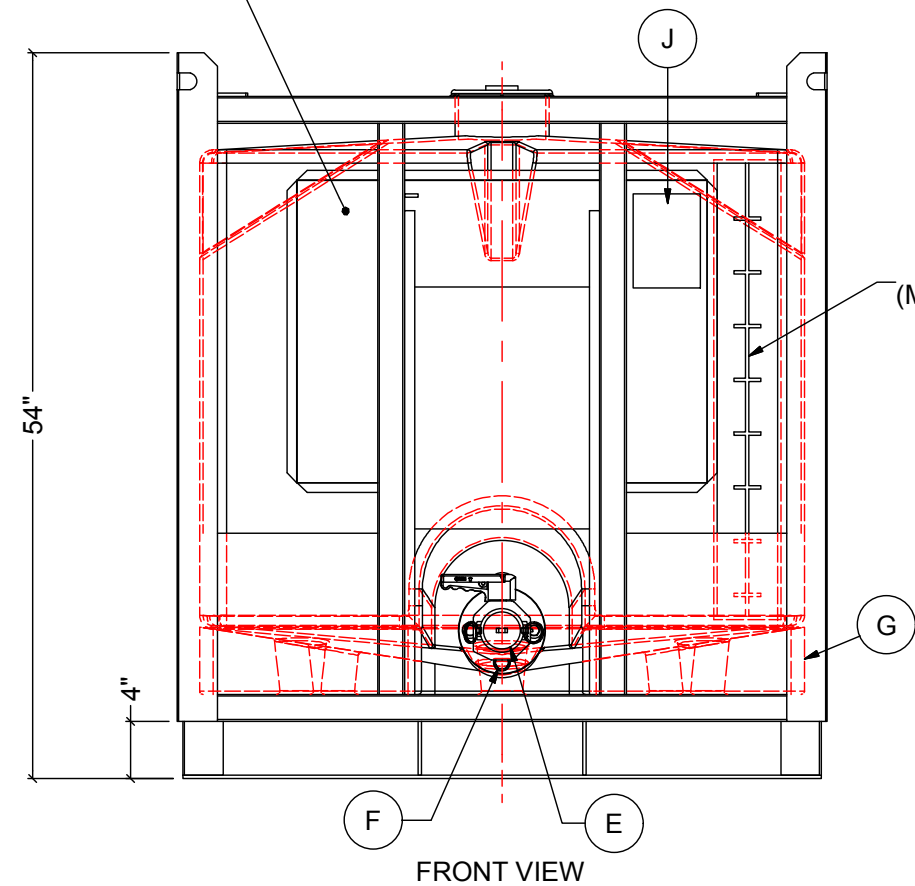

GRADUATIONS (MOLDED IN BOTTLE)

FRONT VIEW

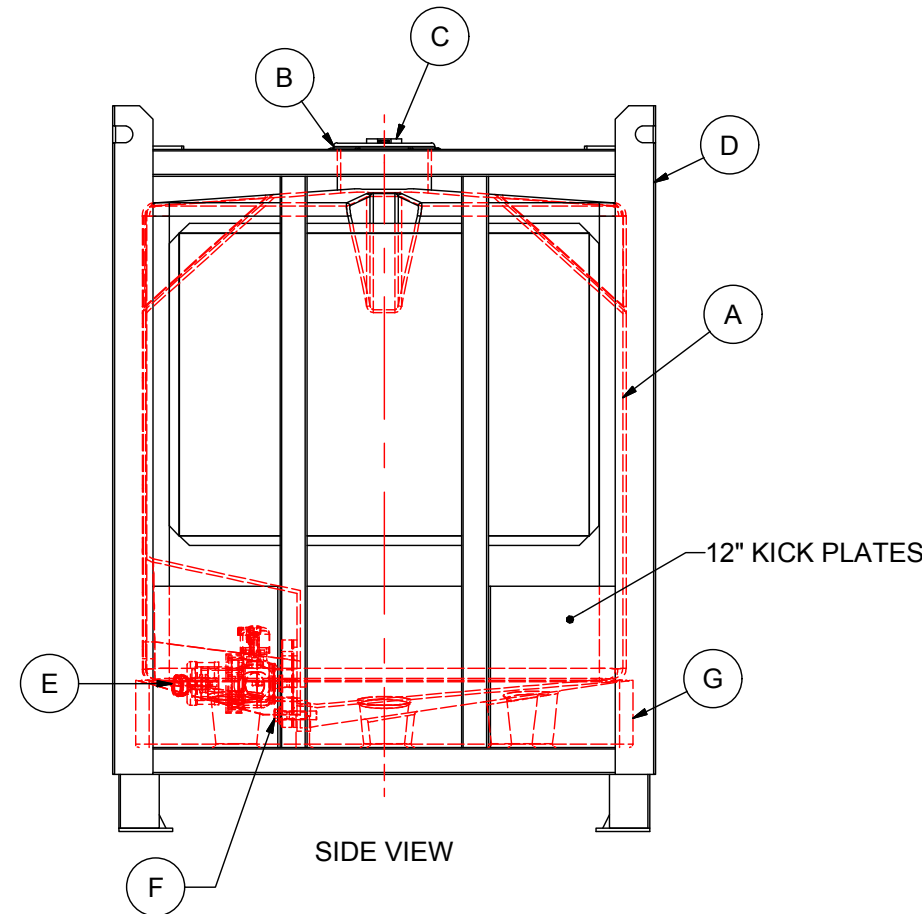

SIDE VIEW

REV	DATE	DESCRIPTION	BY	APPD	REVD
REVISIONS					
CUSTOMER					
TITLE		ACO JOB NO:			
200 IG PALLET TANK WITH 12" KICK PLATES		PURCHASE ORDER NO:			
		PURCHASER'S EQUIP. NO:			
THIS DRAWING IS THE PROPERTY OF ROTOPLAST INC. AND SHALL NOT BE COPIED OR TRANSFERRED WITHOUT THE WRITTEN CONSENT OF ROTOPLAST INC.					
ENGINEERS SEAL		ACO CONTAINER SYSTEMS DIVISION OF ROTOPLAST INC. <small>PICKERING - ONTARIO - CANADA</small> ACO CONTAINER SYSTEMS DIVISION OF ROTOPLAST INC. 794 MCKAY RD. PICKERING, ONTARIO, CANADA TEL. 905-683-8222 FAX 905-683-2969 DWG No			
		DESIGNED		WM	
		DRAWN			
		CHECKED			
		APPROVED			
		SCALE		N.T.S.	
		DATE		15-03-16	
		PTC-200		REV 0	