

FRONT VIEW

NOTES:

1. TANK IS MANUFACTURED FROM HDPE OR XLPE. (1.5, 1.9, OR 2.2 SG)
2. TANK IS MANUFACTURED TO ASTM-D-1998 STANDARD.
3. ALL TANK DIMENSIONS ARE SUBJECT TO A +/-3% TOLERANCE.
4. FLEXIBLE COUPLINGS ARE REQUIRED FOR ALL EXTERNAL PIPING.
5. ALL FITTING GASKETS ARE EPDM OR VITON.
6. ACO RECOMMENDS ALL FLANGE GASKETS TO BE MIN. 1/4" THICK.
7. ON LARGER SIZED TANKS SOME MECHANICAL FITTINGS MAY NEED TO BE REMOVED IN ORDER TO AVOID WIDE OR OVERSIZED LOADS.
8. HDPE ALIGNMENT WEDGES ARE REQUIRED ON SOME TOP FITTINGS TO KEEP THEM PERPENDICULAR TO THE GROUND.
9. TANK MUST BE PROPERLY VENTED TO PREVENT PRESSURE OR VACUUM FROM DEVELOPING AS THE TANK IS FILLING OR EMPTYING.
10. ONLY ONE BOTTOM OUTLET FITTING MAY BE INSTALLED.
11. BOTTOM OUTLET FITTING MAY ONLY BE INSTALLED ON A FITTING FLAT LOCATED AT 0°, 90°, 180° OR 270°.
12. CONTAINMENT TANK IS 1.5SG AS STANDARD.

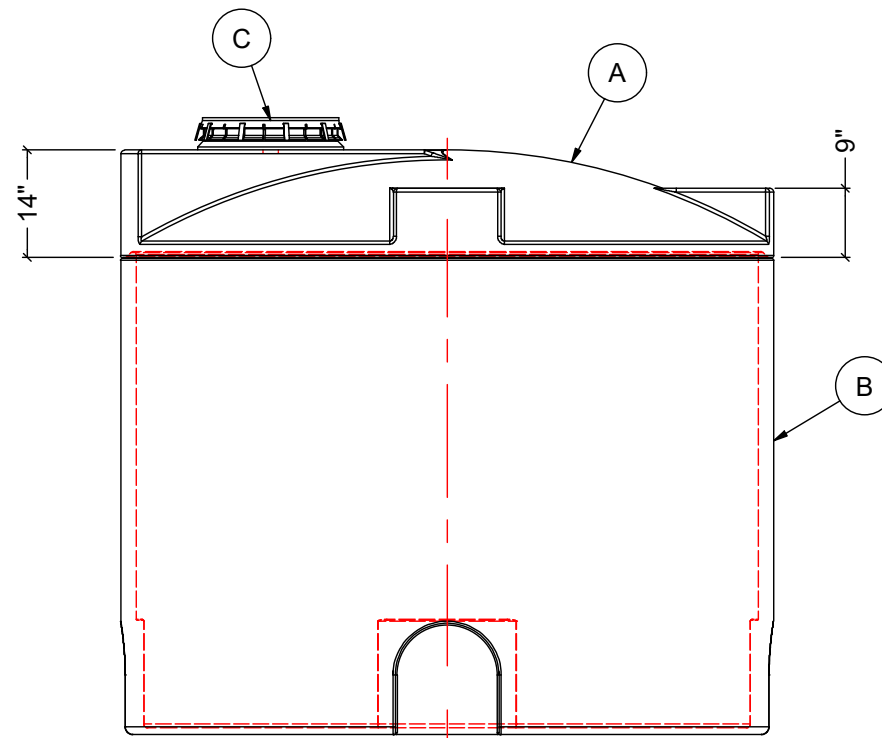

SIDE VIEW

MATERIALS LIST		
ITEMS	DESCRIPTION	NOTES
A	DMT-1000 PRIMARY TANK	
B	DMT-1000 CONTAINMENT TANK	
C	16" LID WITH LOCKING STRAP	

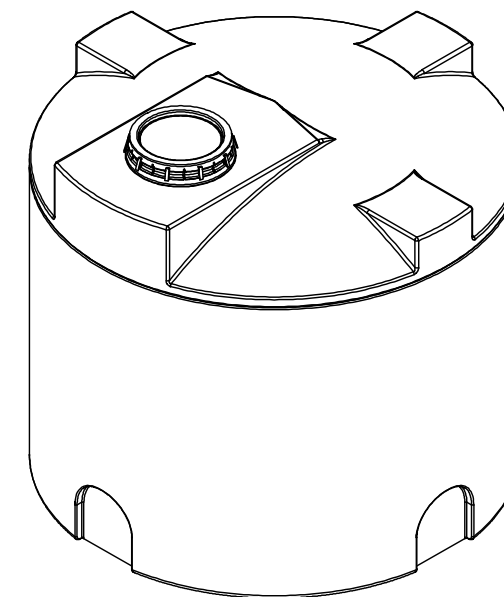

REV	DATE	DESCRIPTION	BY	APPD	REVD
1	NOV-12-21	RELOCATED LID	WM		

CUSTOMER

TITLE: 1000 IG / 1200 USG / 4500 L DOUBLE WALL TANK
 ACO JOB NO: _____
 PO#: _____
 EQUIP. NO: _____

THIS DRAWING IS THE PROPERTY OF ROTOPLAST INC. AND SHALL NOT BE COPIED OR TRANSFERRED WITHOUT THE WRITTEN CONSENT OF ROTOPLAST INC.



ENGINEERS SEAL	ACO CONTAINER SYSTEMS DIVISION OF ROTOPLAST INC. 794 MCKAY ROAD PICKERING, ONTARIO, CANADA TEL: 905-683-8222 WEB: ACOTAINERS.COM	DESIGNED	WM
		DRAWN	
		CHECKED	
		APPROVED	
		SCALE	N.T.S.
		DATE	JAN-18-2021