

- NOTES:
1. TANK IS MANUFACTURED FROM HDPE.
 2. TANK IS MANUFACTURED TO ASTM-D-1998 STANDARD.
 3. 1/4" NOMINAL THICKNESS.

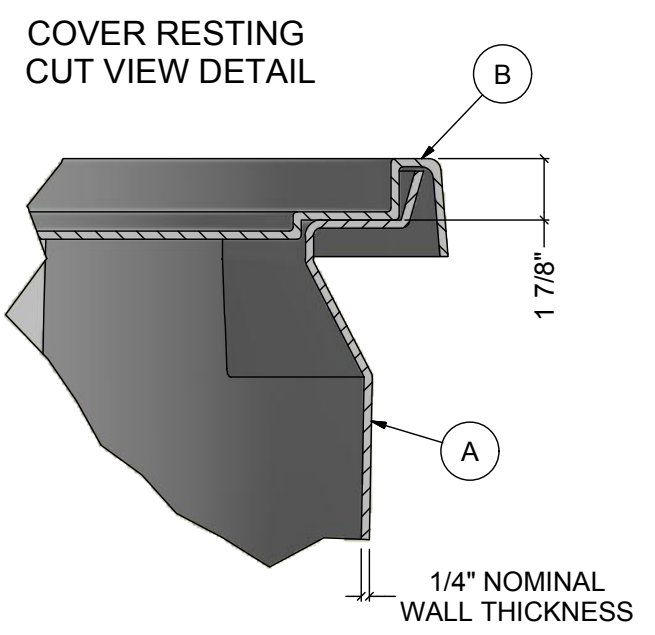

MATERIALS LIST		
ITEMS	DESCRIPTION	NOTES
A	270IG HDPE MATERIAL HANDLING BIN WITH MOLDED IN FORKLIFT CHANNELS	
B	HDPE COVER FOR 270IG MATERIAL HANDLING BIN	

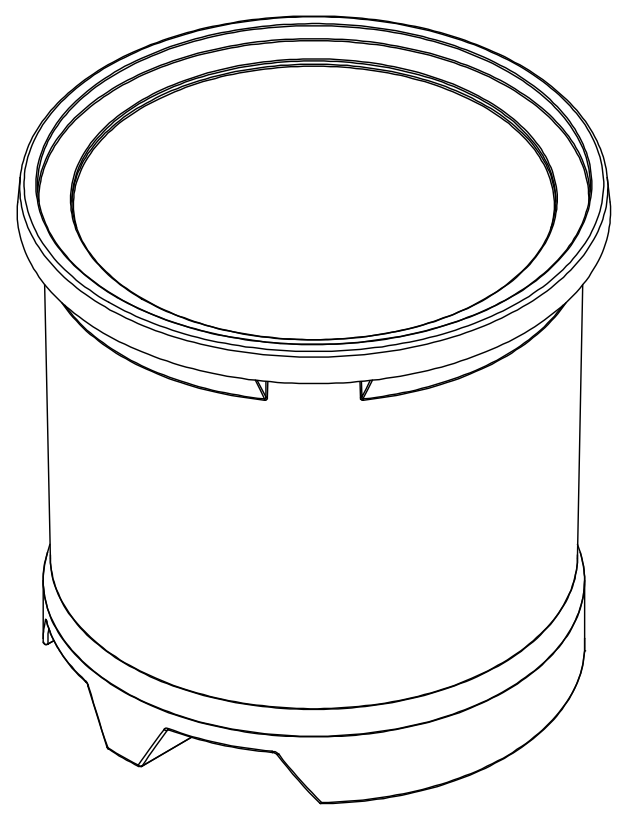

ISOMETRIC VIEW
WITH COVER

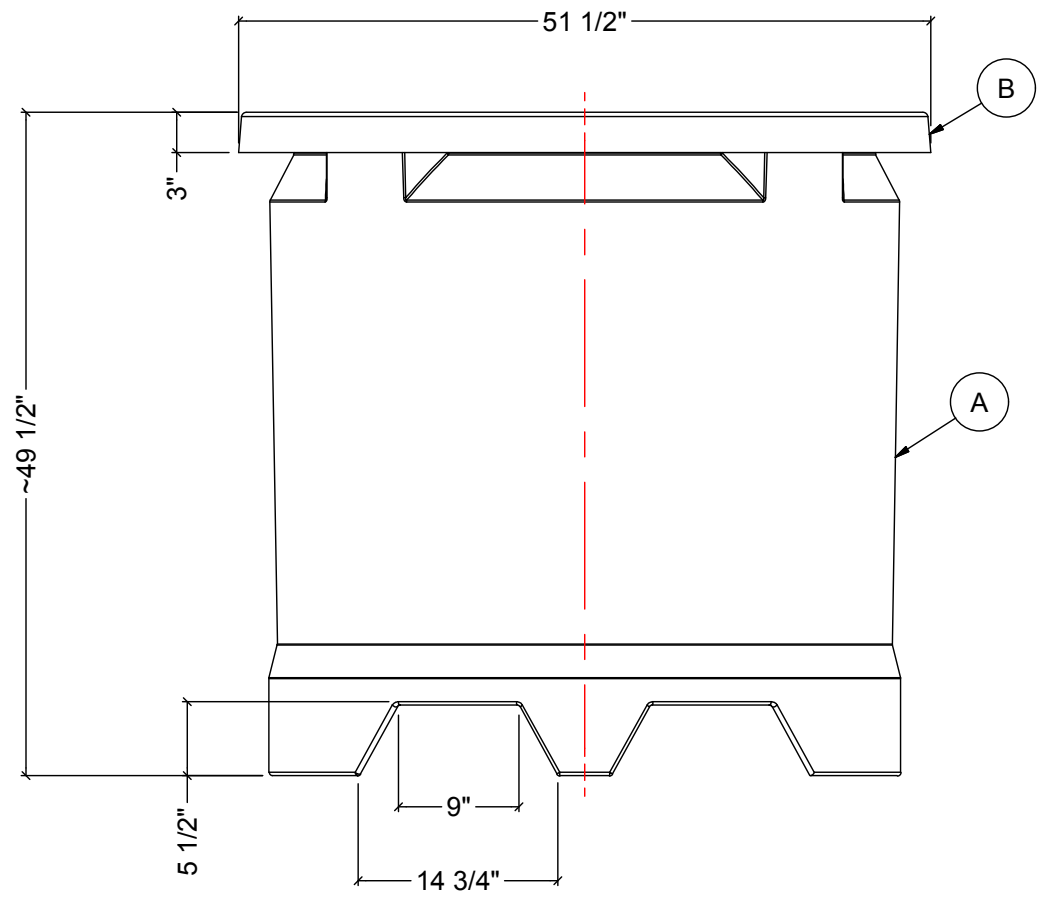

FRONT VIEW
WITH COVER

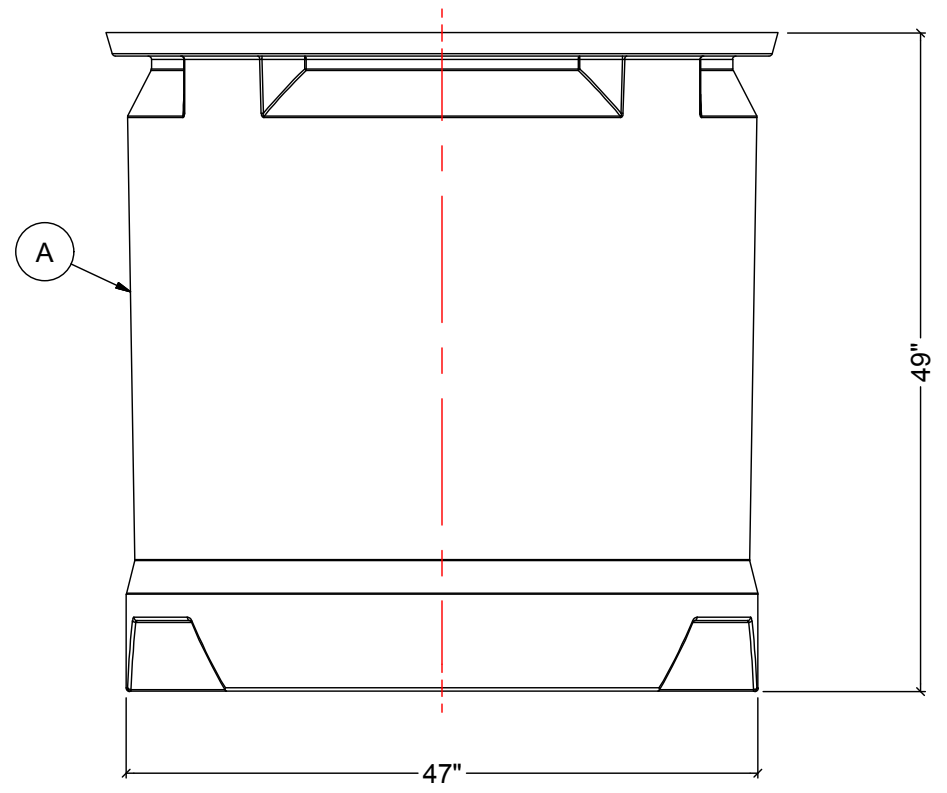

SIDE VIEW
NO COVER

REV	DATE	DESCRIPTION	BY	APPD	REVD
REVISIONS					
CUSTOMER					
TITLE		ACO JOB NO:			
270 IG MATERIAL HANDLING BIN		PURCHASE ORDER NO:			
		PURCHASER'S EQUIP. NO:			
THIS DRAWING IS THE PROPERTY OF ROTOPLAST INC. AND SHALL NOT BE COPIED OR TRANSFERRED WITHOUT THE WRITTEN CONSENT OF ROTOPLAST INC.					
ENGINEERS SEAL		ACO CONTAINER SYSTEMS DIVISION OF ROTOPLAST INC.			
<small>PICKERING - ONTARIO - CANADA</small>					
<small>ACO CONTAINER SYSTEMS DIVISION OF ROTOPLAST INC. 794 MCKAY RD. PICKERING, ONTARIO, CANADA TEL. 905-683-8222 FAX 905-683-2969</small>		DESIGNED			
		DRAWN	WM		
		CHECKED			
		APPROVED			
		SCALE		N.T.S.	
		DATE		03-06-16	
DWG No		MH-270			REV 0