

MATERIALS LIST		
ITEMS	DESCRIPTION	NOTES
A	160 IG OPEN TOP MATERIAL HANDLING CONTAINER	
B	REMOVABLE COVER FOR MATERIAL HANDLING CONTAINER	

NOTES:

1. TANK IS MANUFACTURED FROM HDPE OR XLPE. (1.5 SG)
2. TANK IS MANUFACTURED TO ASTM-D-1998 STANDARD.
3. MOLDED IN FORKLIFT CHANNELS.
4. 1/4" NOMINAL THICKNESS.

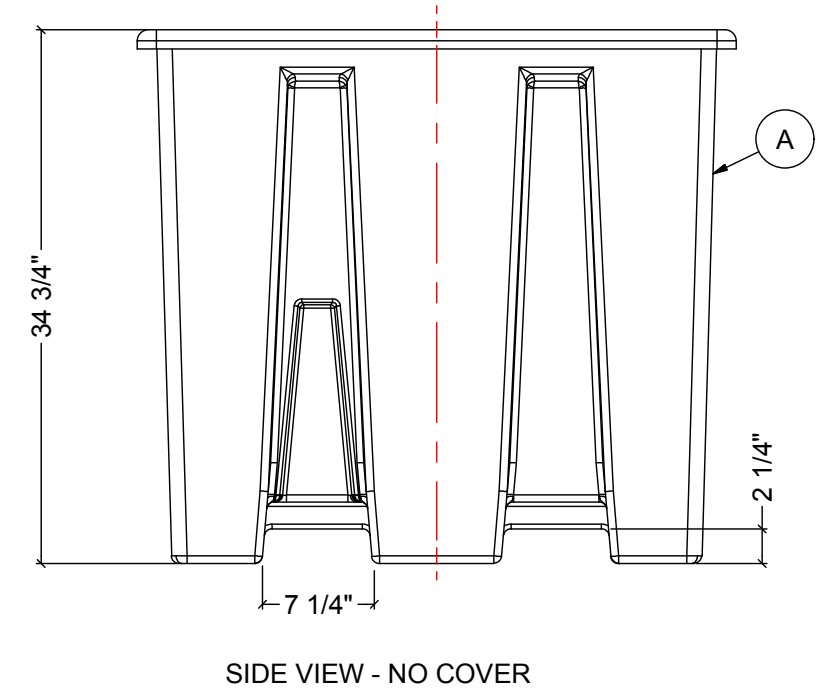
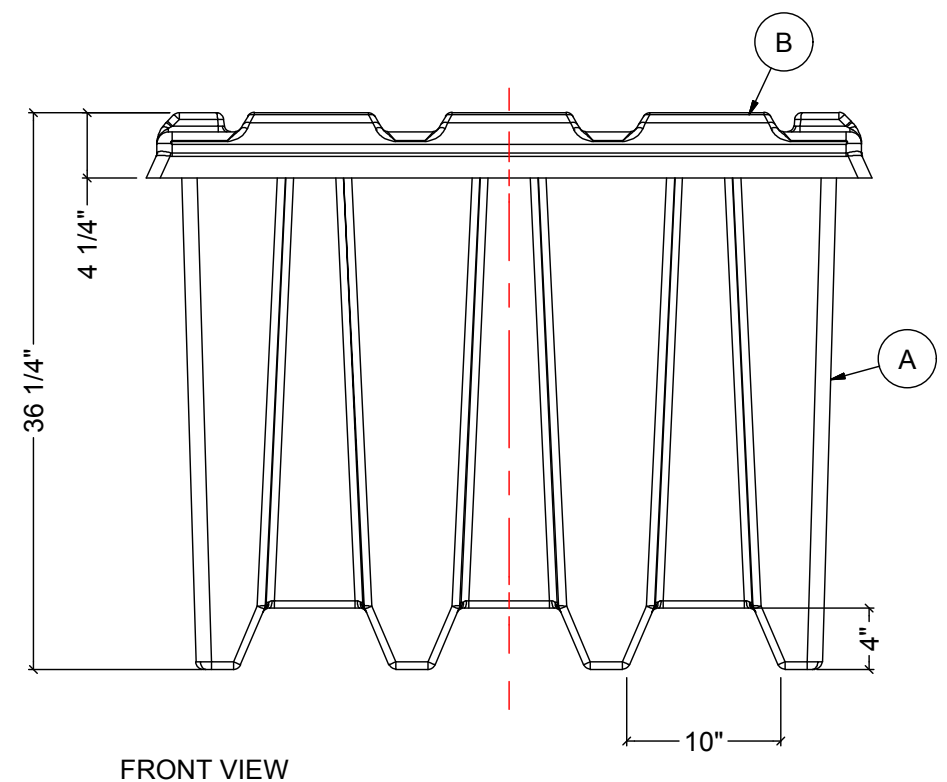
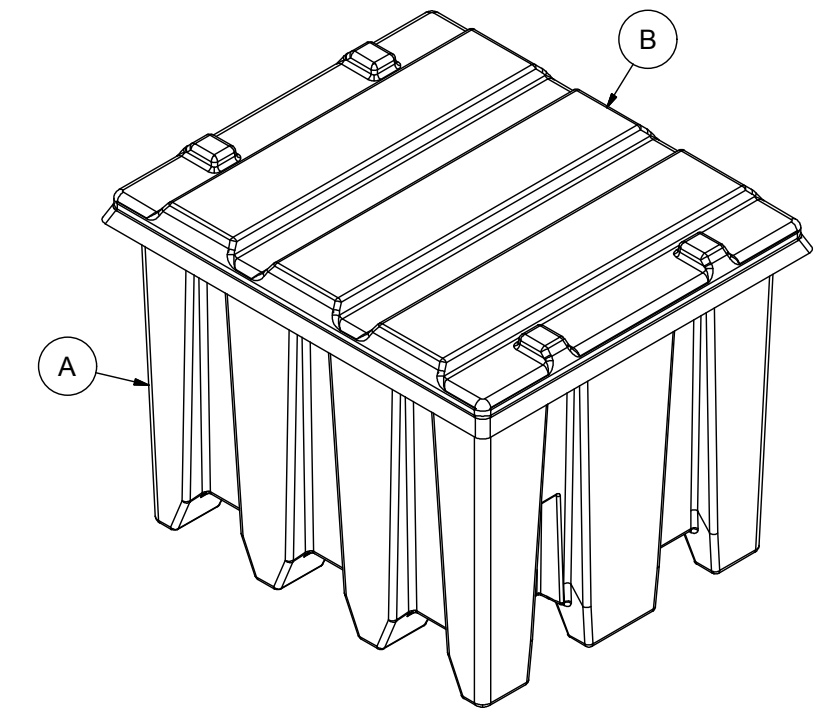
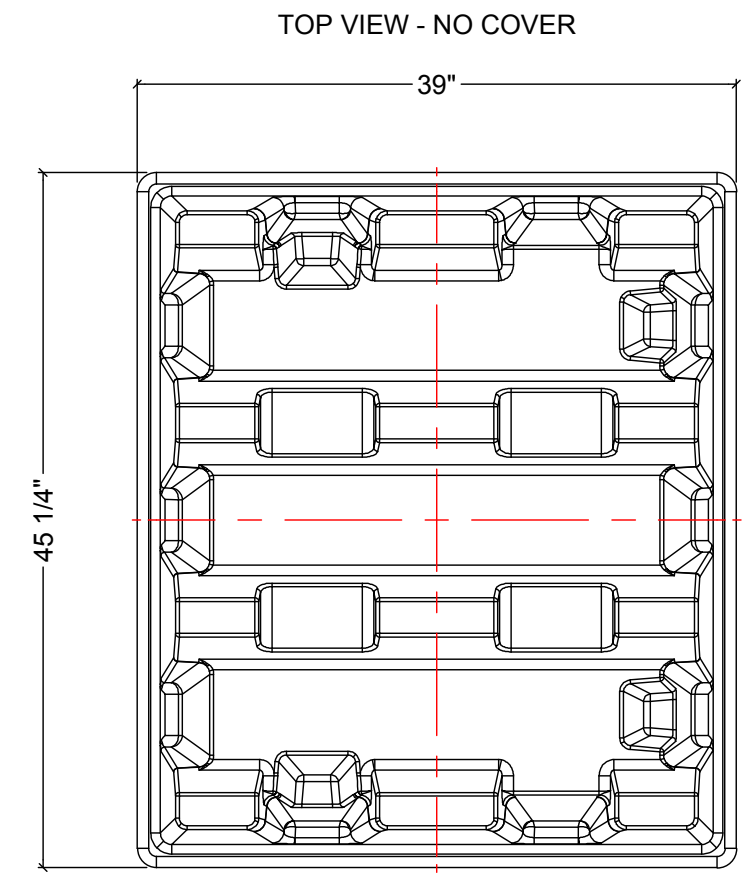
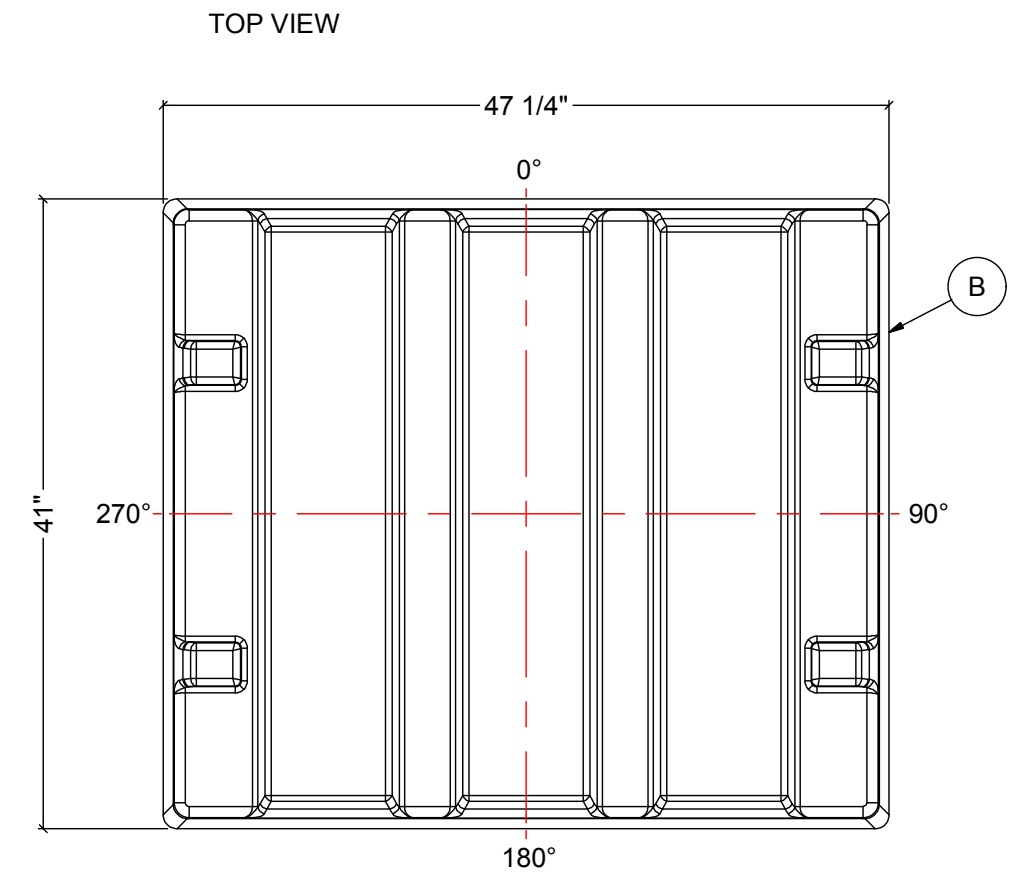

REV	DATE	DESCRIPTION	BY	APPD	REVD
REVISIONS					
CUSTOMER					
TITLE		ACO JOB NO:			
160IG MATERIAL HANDLING CONTAINER		PURCHASE ORDER NO:			
		PURCHASER'S EQUIP. NO:			
THIS DRAWING IS THE PROPERTY OF ROTOPLAST INC. AND SHALL NOT BE COPIED OR TRANSFERRED WITHOUT THE WRITTEN CONSENT OF ROTOPLAST INC.					
ENGINEERS SEAL		<b>ACO CONTAINER SYSTEMS</b> DIVISION OF ROTOPLAST INC.			
<small>PICKERING - ONTARIO - CANADA</small>					
<small>ACO CONTAINER SYSTEMS DIVISION OF ROTOPLAST INC. 794 MCKAY RD. PICKERING, ONTARIO, CANADA TEL. 905-683-8222 FAX 905-683-2969</small>		DESIGNED			
		DRAWN			WM
		CHECKED			
		APPROVED			
		SCALE			N.T.S.
		DATE			30-09-16
DWG No		<b>MH-160</b>			REV <b>0</b>