

NOTES:

1. CAPACITY: 614 L (135 IG / 162 USG)
2. TARE WEIGHT: 472 LBS (214 KG)
3. PRIMARY MARKINGS: U.N. 31HA1/Y/

STACKING BRACKET DETAIL (G)

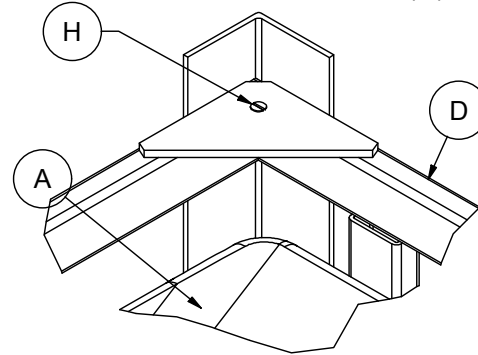

MATERIALS LIST		
ITEMS	DESCRIPTION	NOTES
A	PTC-135 NARROW PROFILE HDPE BOTTLE	
B	6" HDPE THREADED LID WITH GASKET (EPDM OR VITON) AND TIE DOWN	
C	2" COMBI-VENT - VACUUM AND PRESSURE RELEIF (OPTIONAL)	IN LID
D	STEEL FRAME WITH 12" KICK PLATES AND VALVE PROTECTION GATE	
E	2" BALL VALVE (POLYPRO OR STAINLESS STEEL) WITH GASKET (EPDM OR VITON)	FNPT OR CAMLOC
F	VALVE MOUNTING HARDWARE KIT	4 PLACES
G	BLACK POLY FRAME PILLOW	
H	FRAME CORNER STACKING BRACKET WITH SCREW	4 PLACES
J	ALUMINUM U.N. FRAME TAG	

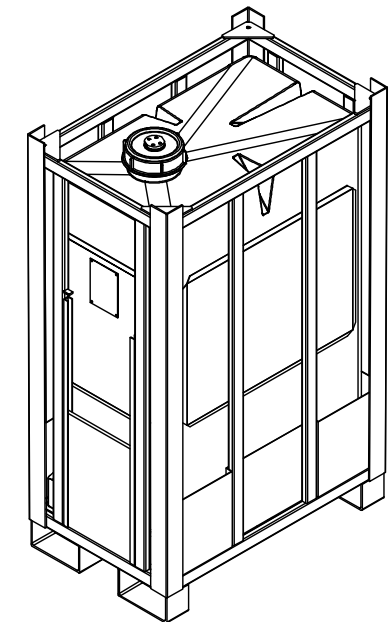
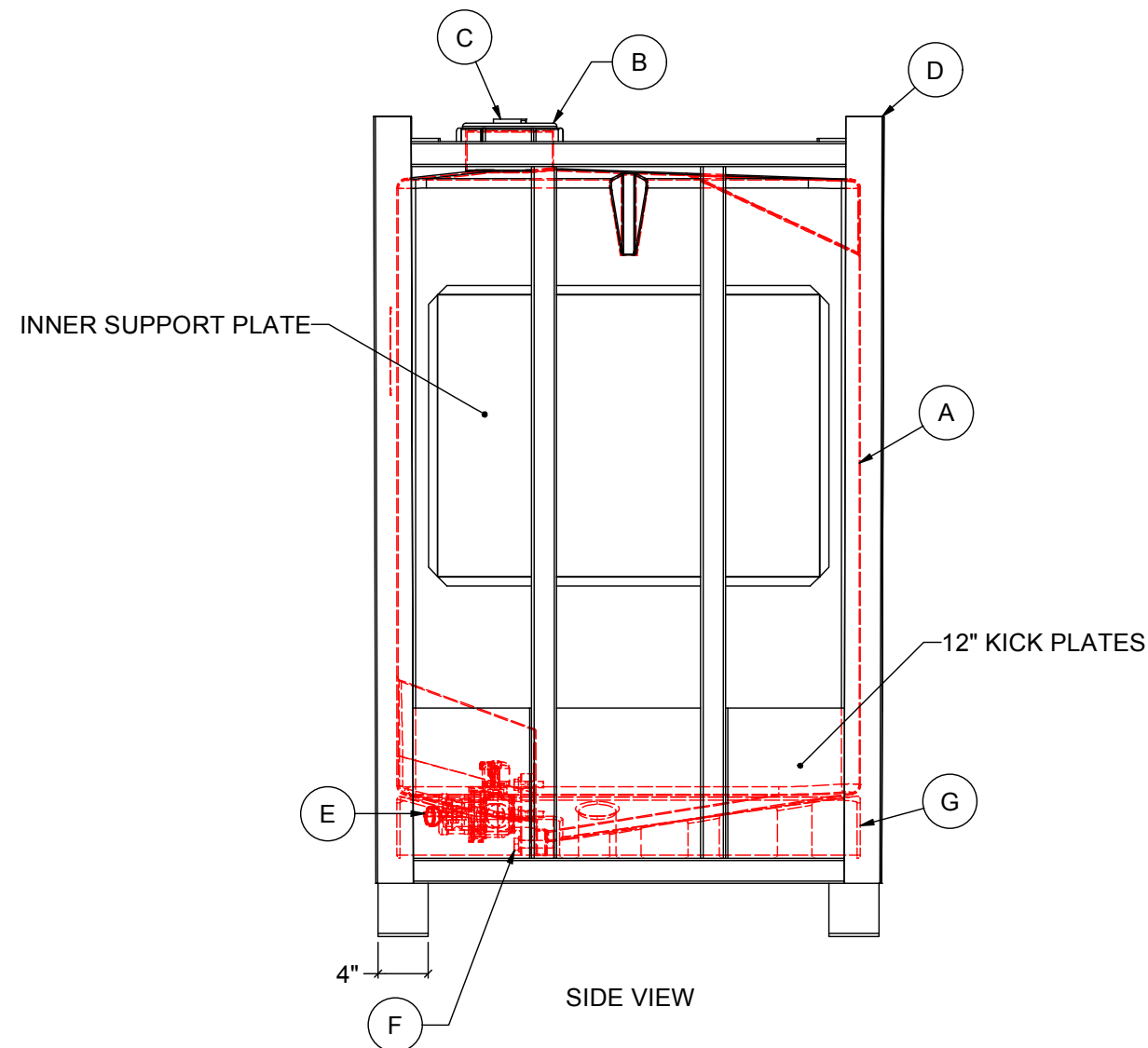
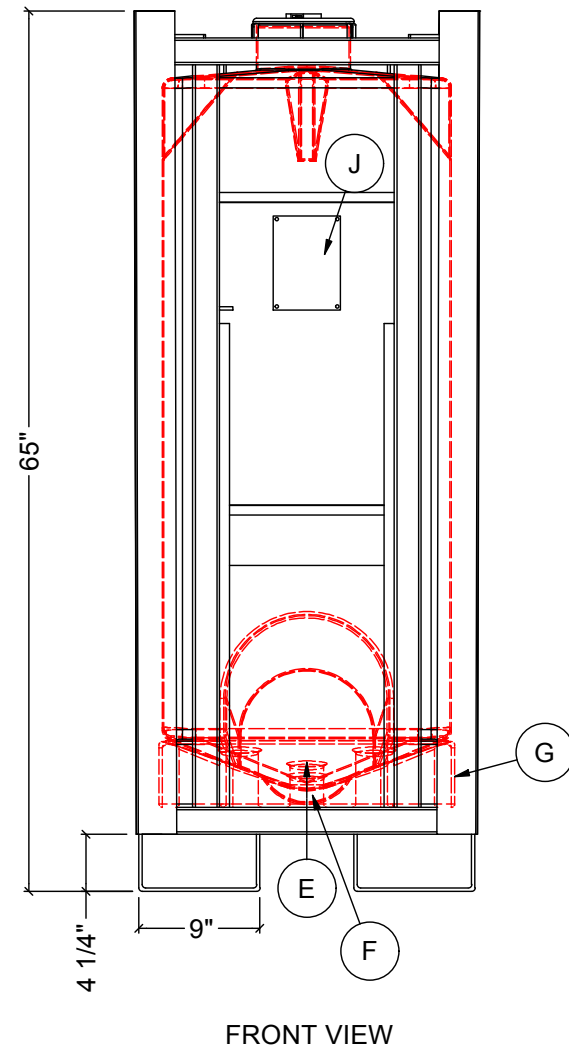

REV	DATE	DESCRIPTION	BY	APPD	REVD
2	FEB-11-20	CORRECTED FRAME	WM		
1	2018-07-09	UPDATED VOLUME AND WEIGHT	WM		

REVISIONS

CUSTOMER

TITLE: PTC-135-NP NARROW PROFILE PALLET TANK WITH 12" KICKPLATES  
 ACO JOB NO:  
 PO#:  
 EQUIP. NO:

THIS DRAWING IS THE PROPERTY OF ROTOPLAST INC. AND SHALL NOT BE COPIED OR TRANSFERRED WITHOUT THE WRITTEN CONSENT OF ROTOPLAST INC.



ENGINEERS SEAL	ACO CONTAINER SYSTEMS DIVISION OF ROTOPLAST INC. 794 MCKAY ROAD PICKERING, ONTARIO, CANADA TEL: 905-683-8222 WEB: ACOTAINERS.COM	DESIGNED DRAWN CHECKED APPROVED SCALE DATE	WM    N.T.S. 04-04-16
----------------	---	---	--------------------------------------