

NOTES:
 1. TANK IS MANUFACTURED TO ASTM-D-1998 STANDARD.
 2. ALL DIMENSIONS ARE APPROXIMATE.
 3. TANK CAPACITY APPROX. 47,200 L / 10,400 IG

MATERIALS LIST		
ITEMS	DESCRIPTION	NOTES
A	DCT-10440 PRIMARY TANK	
B	DCT-10440 CONTAINMENT TANK	
C	15" THREADED LID	

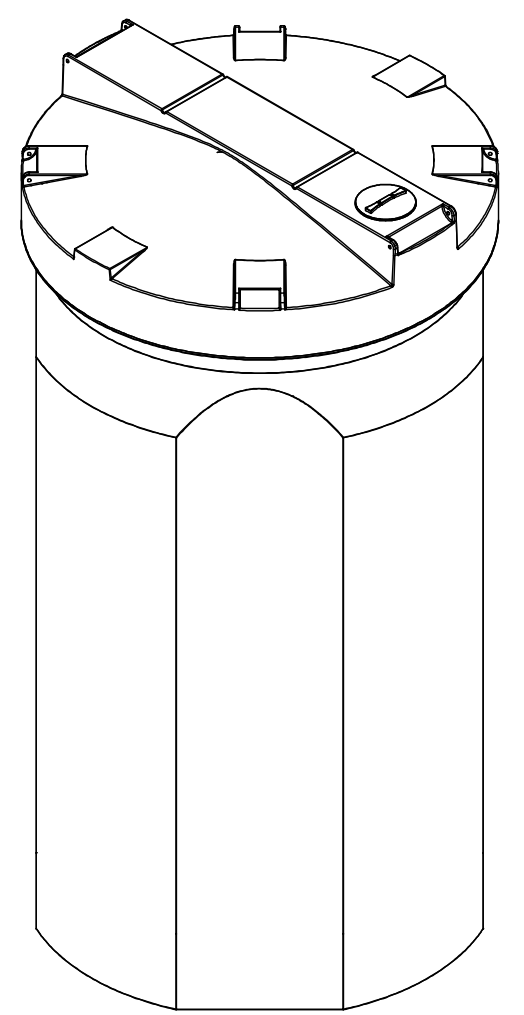
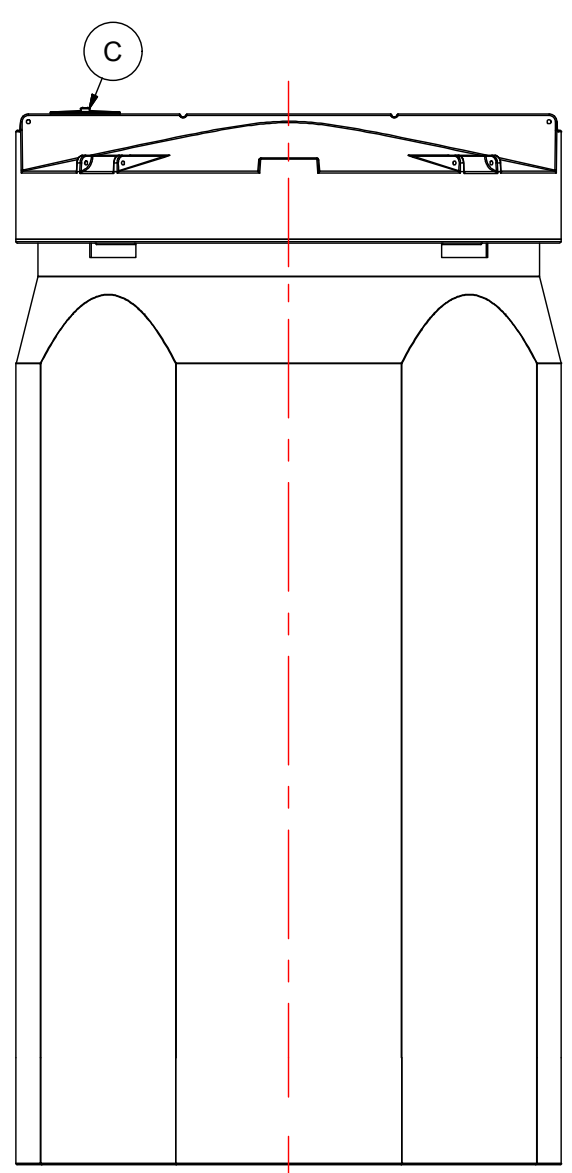
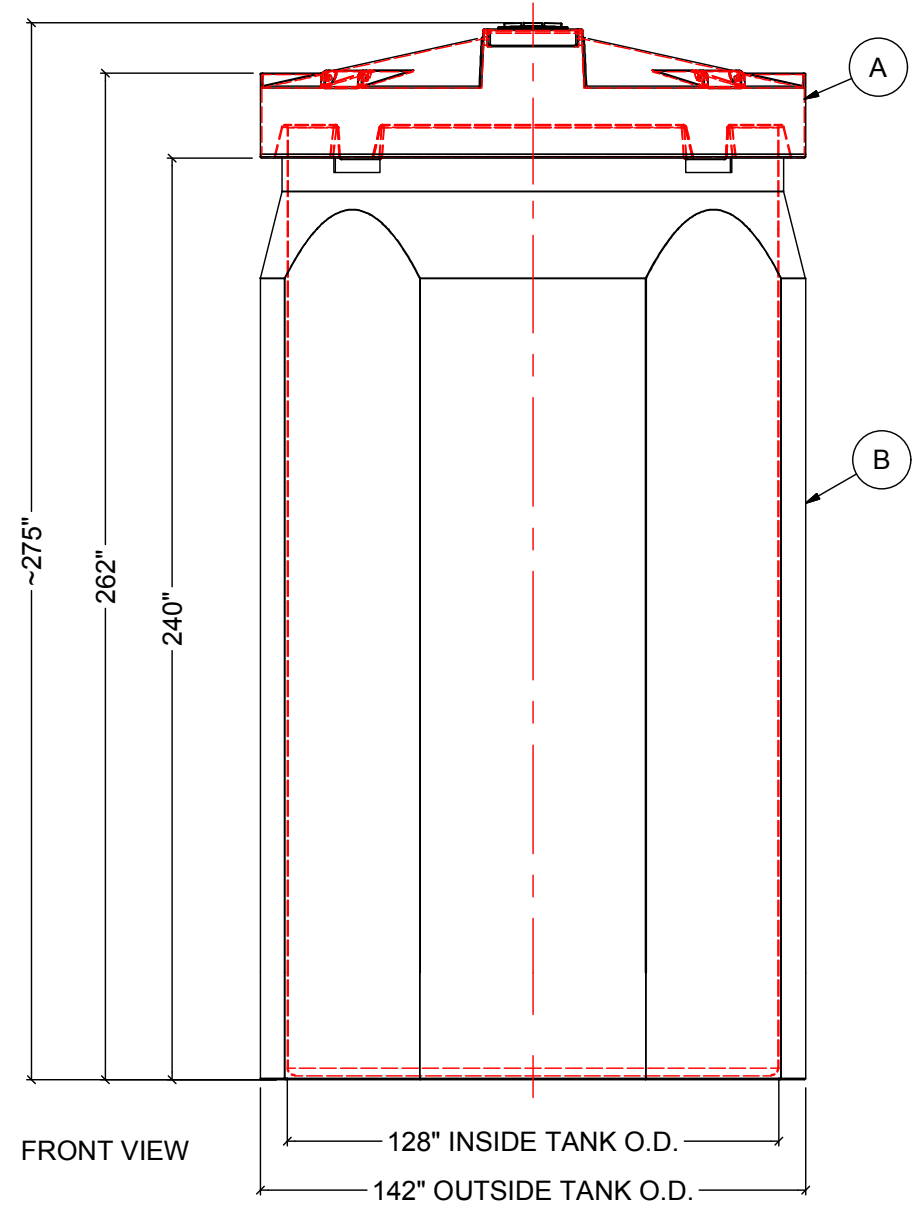

SIDE VIEW

REV	DATE	DESCRIPTION	BY	APPD	REVD
REVISIONS					
CUSTOMER					
TITLE		ACO JOB NO:			
10400 IG DOUBLE WALL TANK		PURCHASE ORDER NO:			
		PURCHASER'S EQUIP. NO:			
THIS DRAWING IS THE PROPERTY OF ROTOPLAST INC. AND SHALL NOT BE COPIED OR TRANSFERRED WITHOUT THE WRITTEN CONSENT OF ROTOPLAST INC.					
ENGINEERS SEAL		ACO CONTAINER SYSTEMS DIVISION OF ROTOPLAST INC.			
PICKERING - ONTARIO - CANADA					
ACO CONTAINER SYSTEMS DIVISION OF ROTOPLAST INC. 794 MCKAY RD. PICKERING, ONTARIO, CANADA TEL. 905-683-8222 FAX 905-683-2969		DESIGNED			
		DRAWN	WM		
		CHECKED			
		APPROVED			
		SCALE		N.T.S.	
		DATE		01-04-16	
DWG No		DCT-10440			REV 0