

TOP VIEW

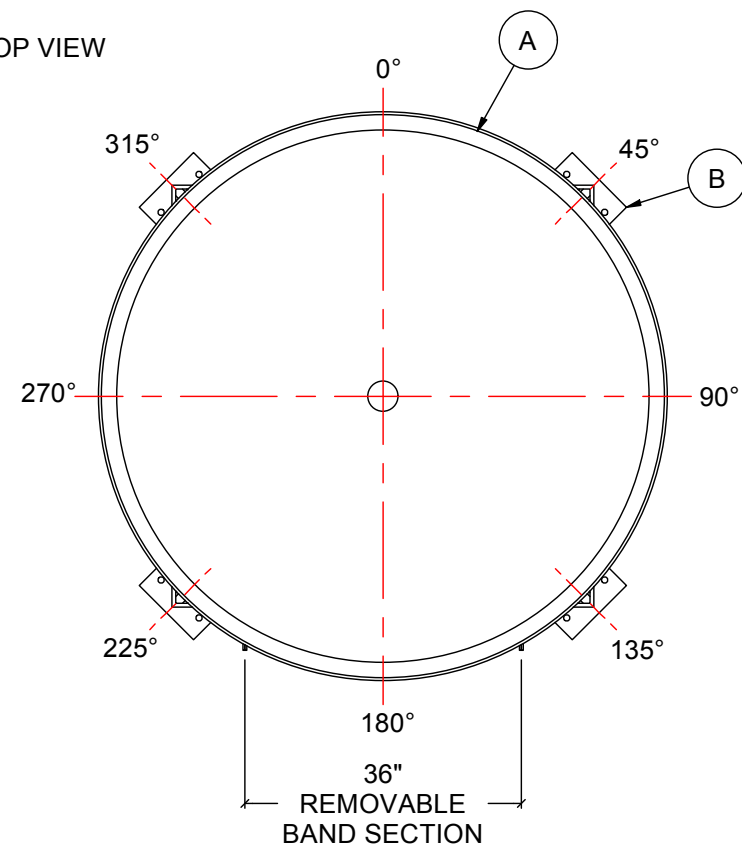

NOTES:

1. TANK IS MANUFACTURED FROM HDPE. (1.5 OR 1.9 OR 2.2 SG)
2. ALL TANK DIMENSIONS ARE SUBJECT TO A +/-3% DIMENSIONAL TOLERANCE.
3. FLEXIBLE COUPLINGS ARE REQUIRED FOR ALL EXTERNAL PIPING.
4. ALL FITTING GASKETS ARE EPDM OR VITON.
5. ACO RECOMMENDS ALL FLANGE GASKETS TO BE MIN. 1/4" THICK.
6. ON LARGER TANKS SOME MECHANICAL FITTINGS MAY NEED TO BE REMOVED IN ORDER TO AVOID WIDE OR OVERSIZED LOADS DURING TRANSPORT.

MATERIALS LIST		
ITEMS	DESCRIPTION	NOTES
A	CBO-1000 CONE BOTTOM OPEN TOP TANK	
B	STEEL STAND FOR CBO-1000	

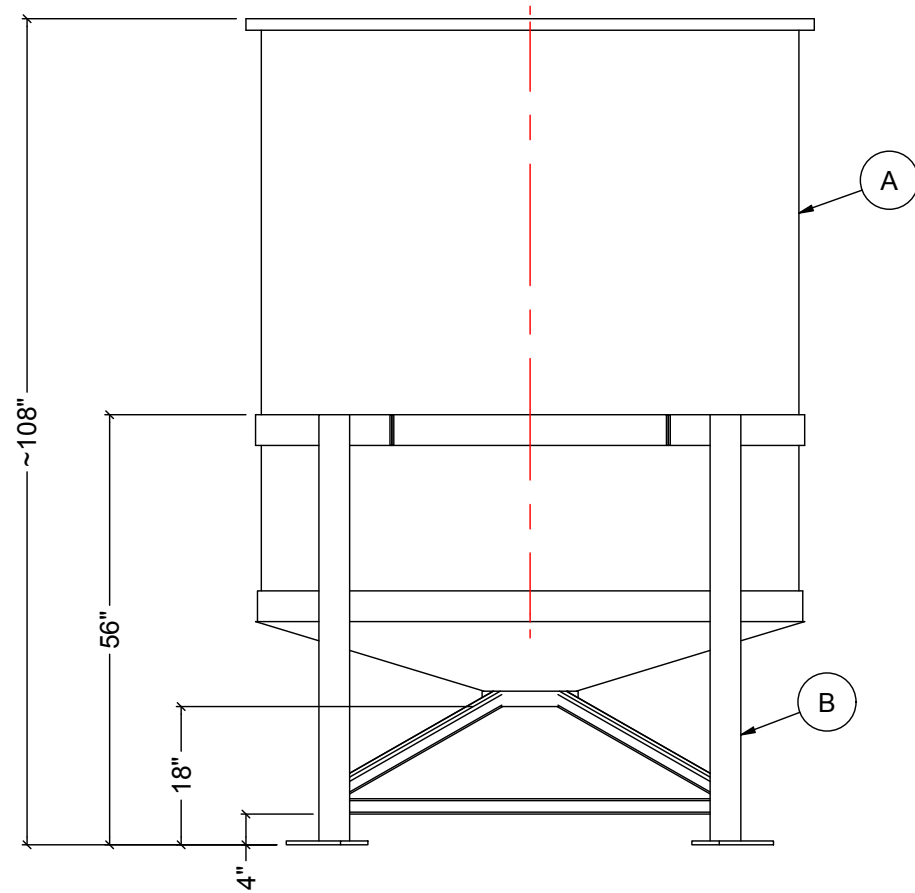
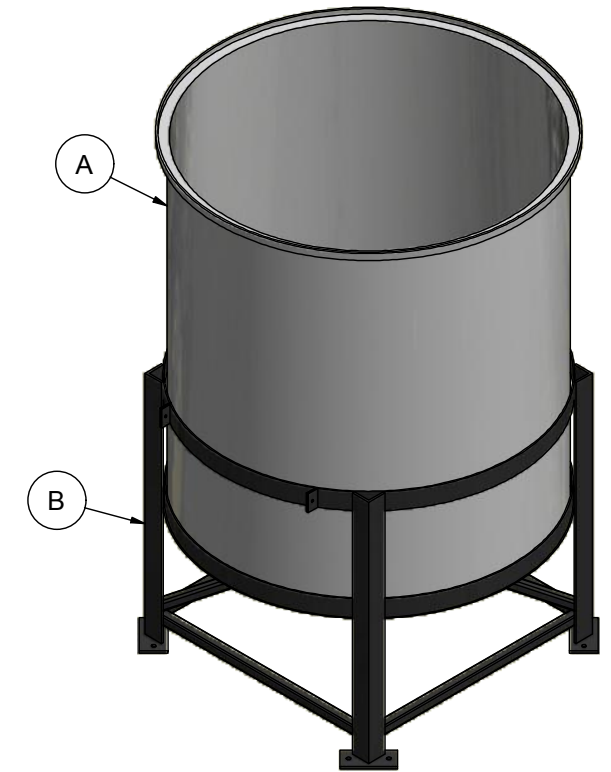

FRONT VIEW

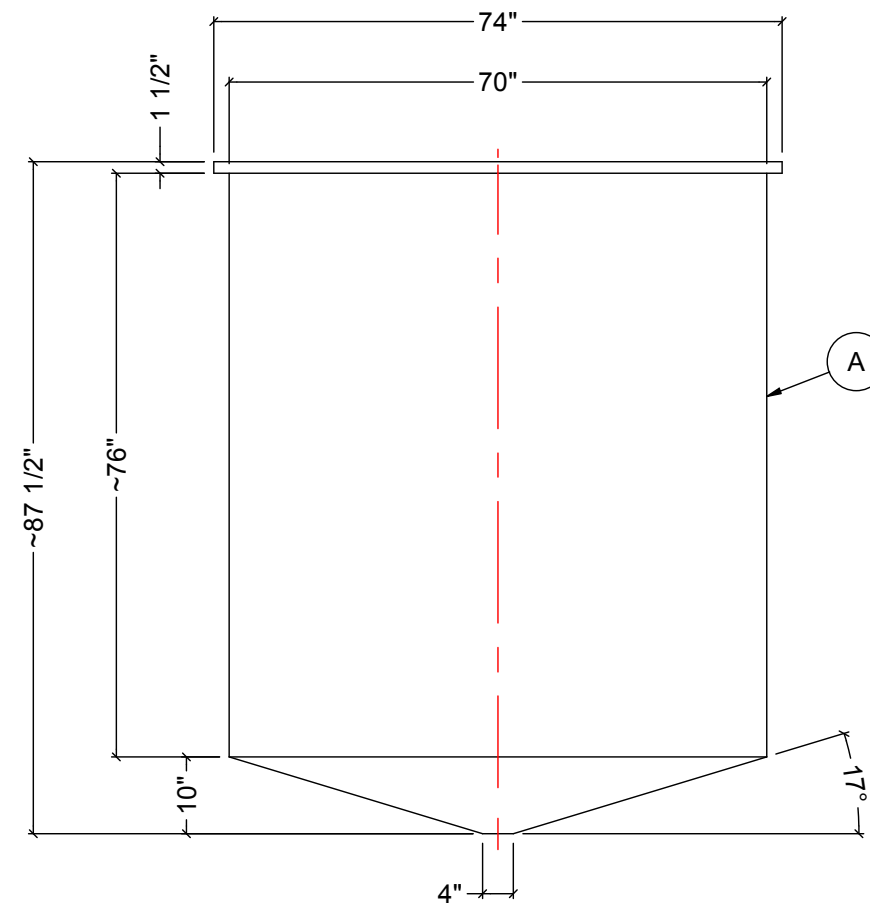

SIDE VIEW - NO STAND

REV	DATE	DESCRIPTION	BY	APPD	REVD
1	JAN-12-20	UPDATED TITLE BLOCK	WM		
REVISIONS					
CUSTOMER					
TITLE			ACO JOB NO:		
1000 IG / 1200 USG / 4500 L OPEN TOP CONE BOTTOM TANK			PO#:		
			EQUIP. NO:		
THIS DRAWING IS THE PROPERTY OF ROTOPLAST INC. AND SHALL NOT BE COPIED OR TRANSFERRED WITHOUT THE WRITTEN CONSENT OF ROTOPLAST INC.			 A division of Rotoplast Inc.		
ENGINEERS SEAL		ACO CONTAINER SYSTEMS DIVISION OF ROTOPLAST INC. 794 MCKAY ROAD PICKERING, ONTARIO, CANADA TEL: 905-683-8222 WEB: ACOTAINERS.COM		DESIGNED	WM
				DRAWN	
				CHECKED	
				APPROVED	
				SCALE	N.T.S.
				DATE	23-03-16
DWG No		CBO-1000			REV 1