

TOP VIEW

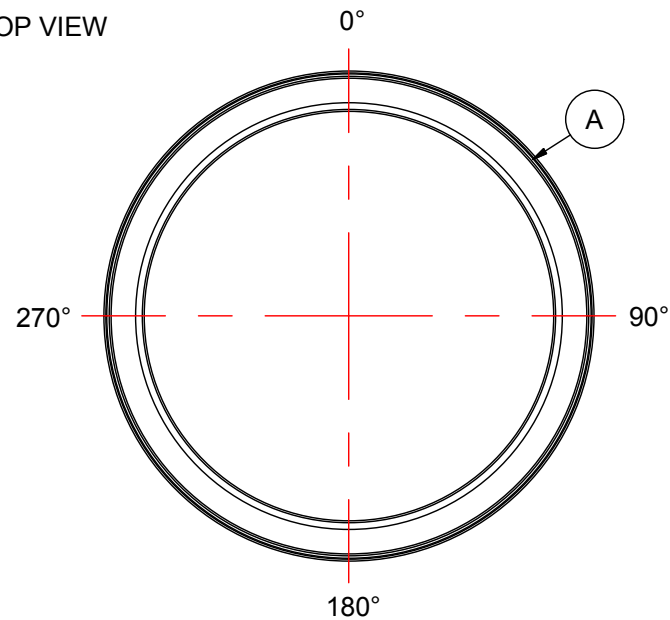

NOTES:

1. TANK IS MANUFACTURED FROM HDPE. (1.9 SG)
2. ALL TANK DIMENSIONS ARE SUBJECT TO A +/-3% DIMENSIONAL TOLERANCE.

LID TOP VIEW

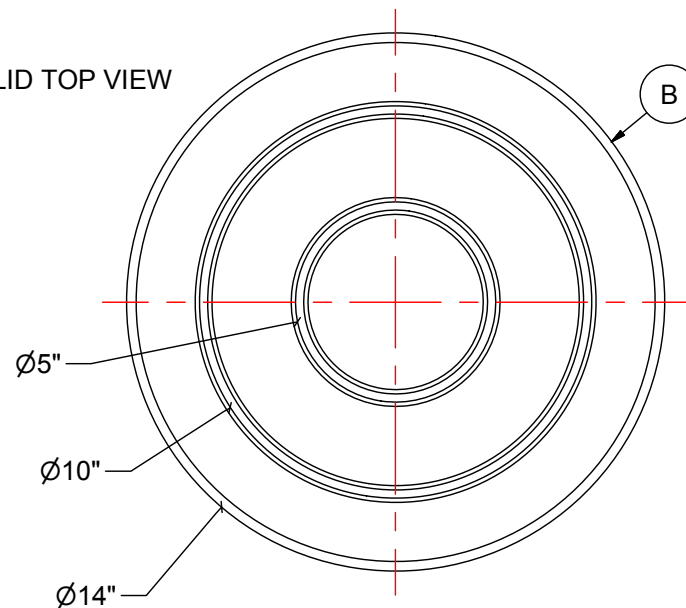

MATERIALS LIST		
ITEMS	DESCRIPTION	NOTES
A	OT-5 OPEN TOP TANK	
B	LID FOR OT-5	

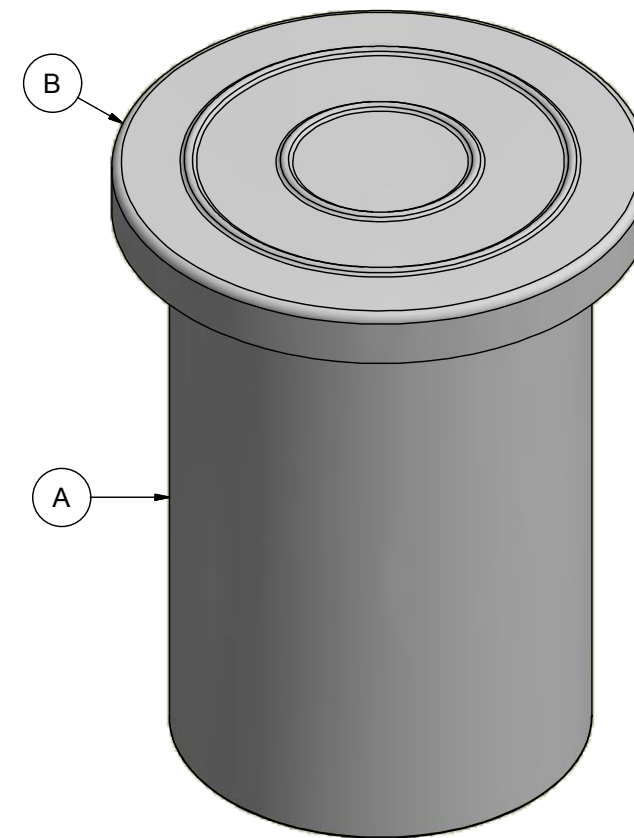
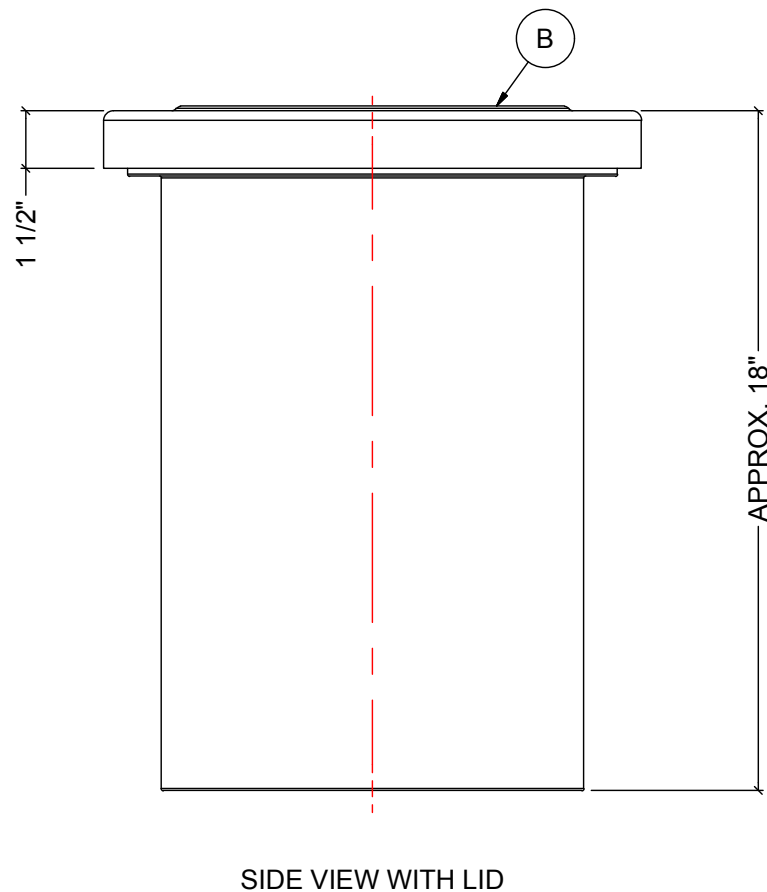
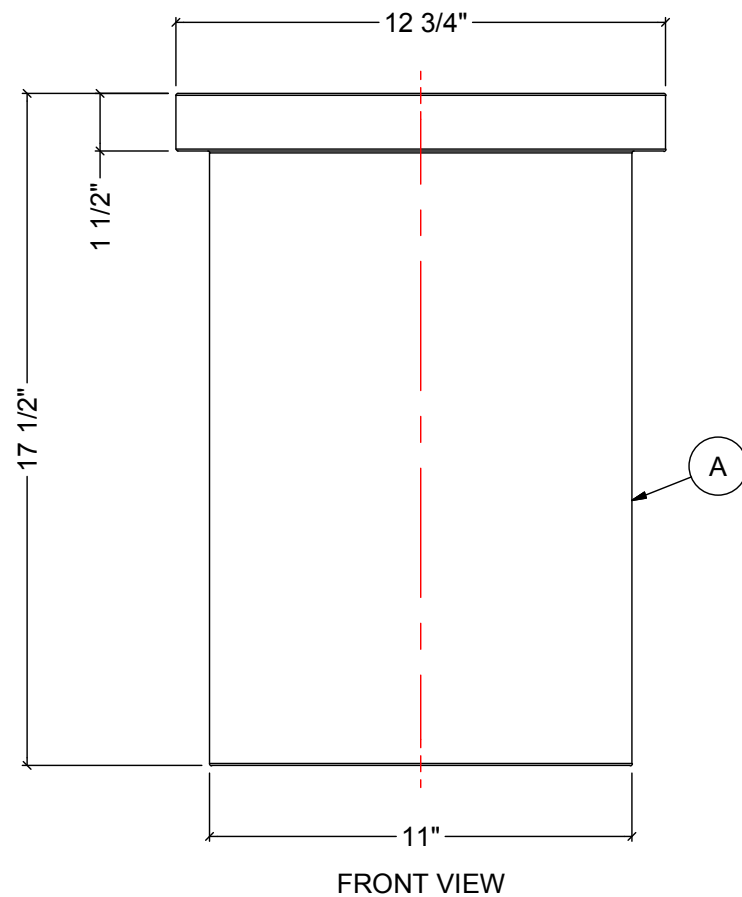

REV	DATE	DESCRIPTION	BY	APPD	REVD
1	JUL-10-19	UPDATED DIMS, ADDED RIDGES TO LID	WM		
REVISIONS					
CUSTOMER					
TITLE			ACO JOB NO:		
5 IG OPEN TOP TANK WITH LID			PURCHASE ORDER NO:		
			PURCHASER'S EQUIP. NO:		
THIS DRAWING IS THE PROPERTY OF ROTOPLAST INC. AND SHALL NOT BE COPIED OR TRANSFERRED WITHOUT THE WRITTEN CONSENT OF ROTOPLAST INC.			 ACO CONTAINER SYSTEMS <i>A division of Rotoplast Inc.</i>		
				DRAWN	WM
				CHECKED	
				APPROVED	
				SCALE	N.T.S.
				DATE	03-03-16
DWG No			OT-5-L		REV 1