

MATERIALS LIST		
ITEMS	DESCRIPTION	NOTES
A	CBC-9640 CONE BOTTOM TANK	
B	15" THREADED LID	
C	STEEL STAND FOR CBC-9640	

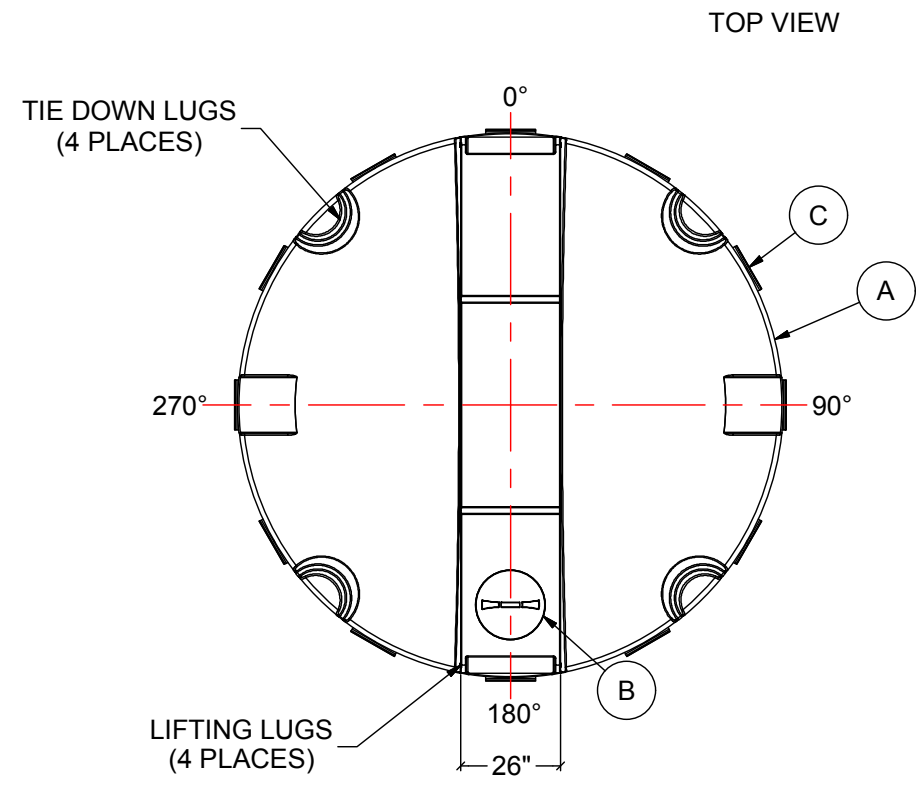

- NOTES:
1. TANK IS MANUFACTURED FROM HDPE. (1.5 SG)
  2. TANK IS MANUFACTURED TO ASTM-D-1998 STANDARD.
  3. ACO RECOMMENDS ALL FLANGE GASKETS TO BE MIN. 1/4" THICK.
  4. ALL FITTING GASKETS ARE EPDM.
  5. ON LARGER SIZED TANKS SOME MECHANICAL FITTINGS MAY NEED TO BE REMOVED IN ORDER TO AVOID WIDE OR OVERSIZED LOADS.

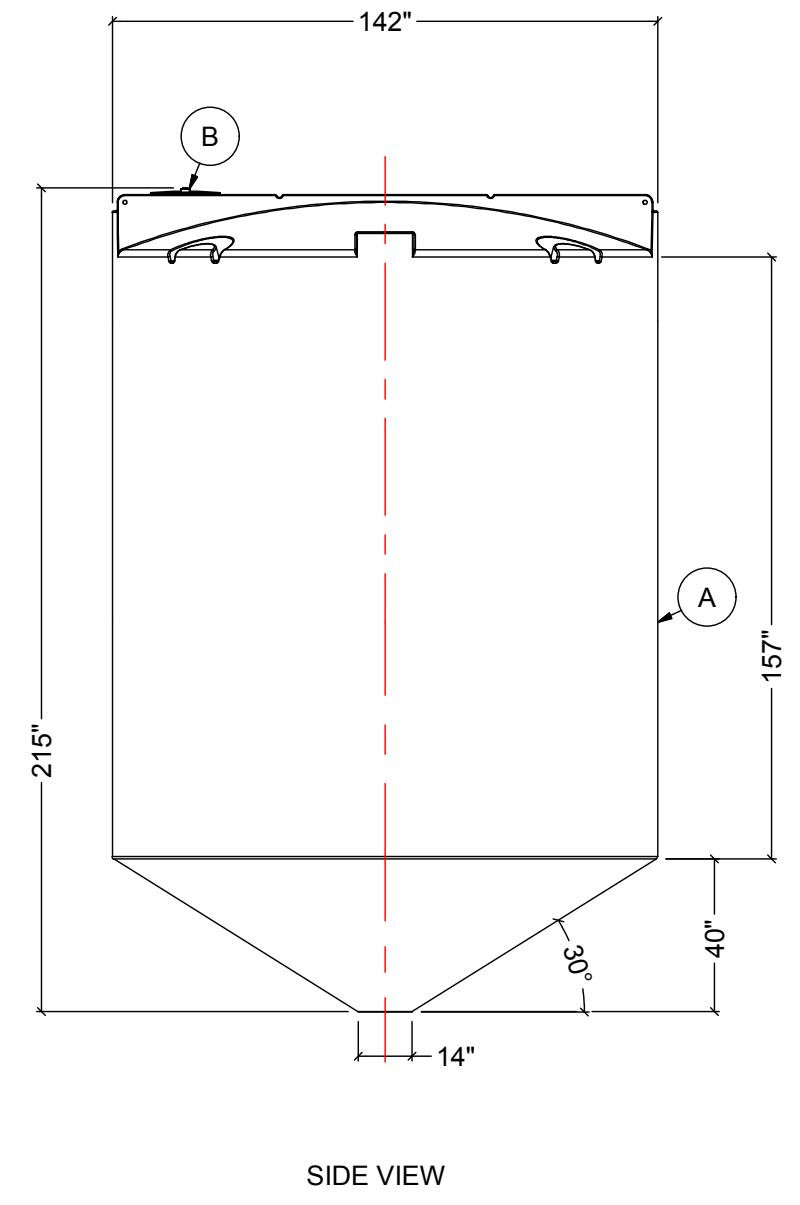
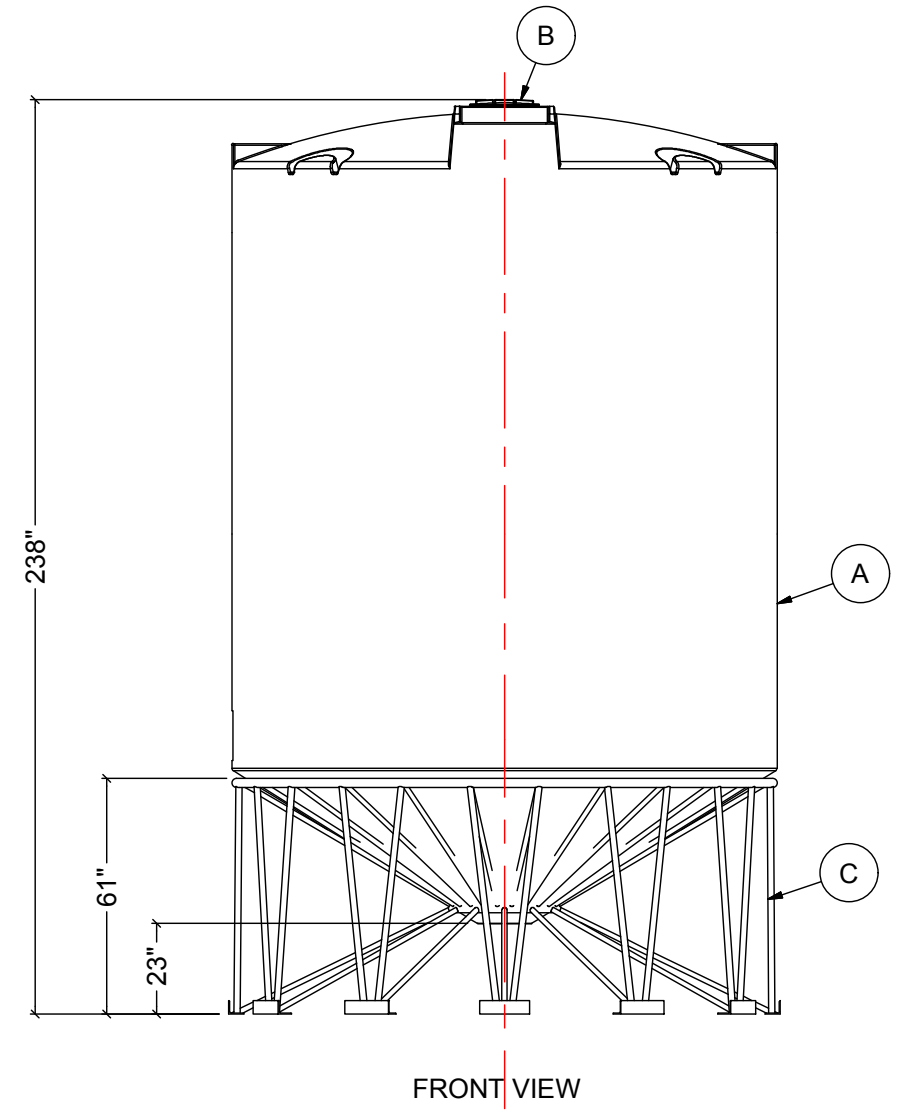
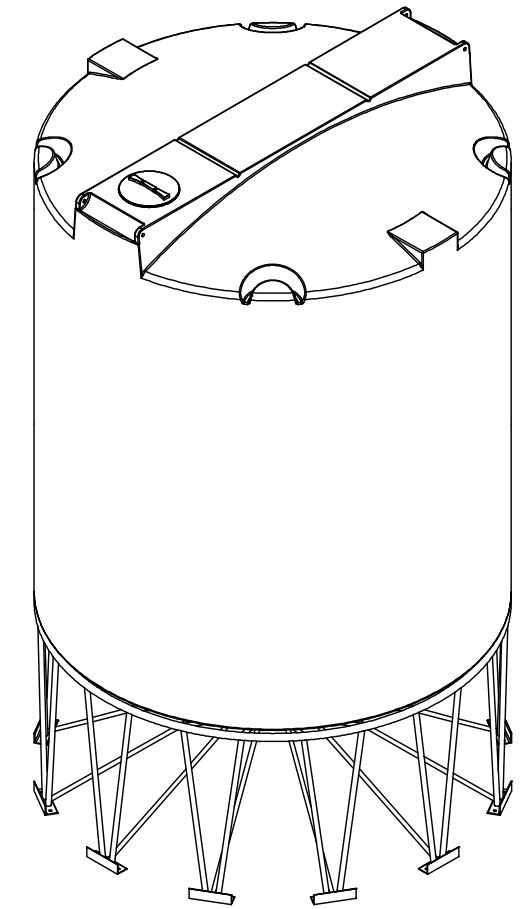

REV	DATE	DESCRIPTION	BY	APPD	REVD
REVISIONS					
CUSTOMER					
TITLE		ACO JOB NO:			
9600 IG CONE BOTTOM TANK		PURCHASE ORDER NO:			
		PURCHASER'S EQUIP. NO:			
THIS DRAWING IS THE PROPERTY OF ROTOPLAST INC. AND SHALL NOT BE COPIED OR TRANSFERRED WITHOUT THE WRITTEN CONSENT OF ROTOPLAST INC.					
ENGINEERS SEAL		<b>ACO CONTAINER SYSTEMS</b> DIVISION OF ROTOPLAST INC. <small>PICKERING - ONTARIO - CANADA</small> ACO CONTAINER SYSTEMS DIVISION OF ROTOPLAST INC. 794 MCKAY RD. PICKERING, ONTARIO, CANADA TEL. 905-683-8222 FAX 905-683-2969 DWG No			
		DESIGNED			
		DRAWN	WM		
		CHECKED			
		APPROVED			
		SCALE	N.T.S.		
		DATE	28-03-16		
		CBC-9640		REV	0