

TOP VIEW

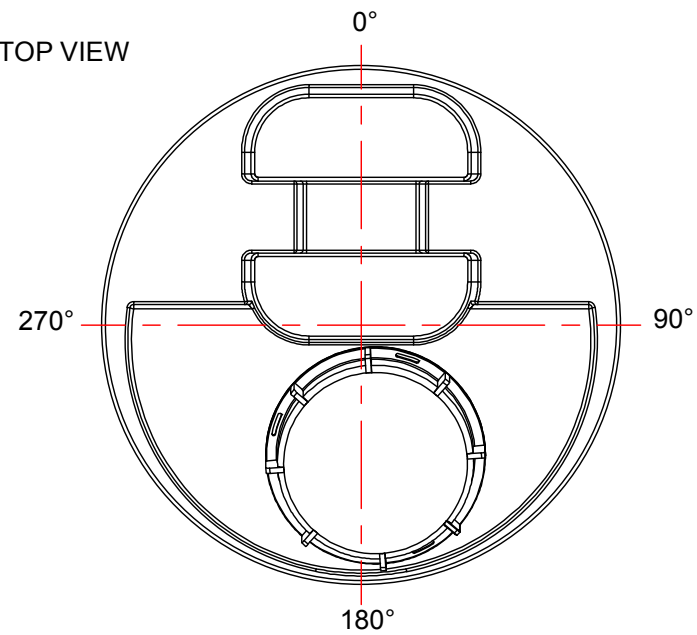

NOTES:

1. TANK IS MANUFACTURED TO ASTM-D-1998 STANDARD.
2. ALL DIMENSIONS ARE APPROXIMATE.

MATERIALS LIST		
ITEMS	DESCRIPTION	NOTES
A	PTB-100 TOTE BARREL	
B	5 1/2" THREADED LID	

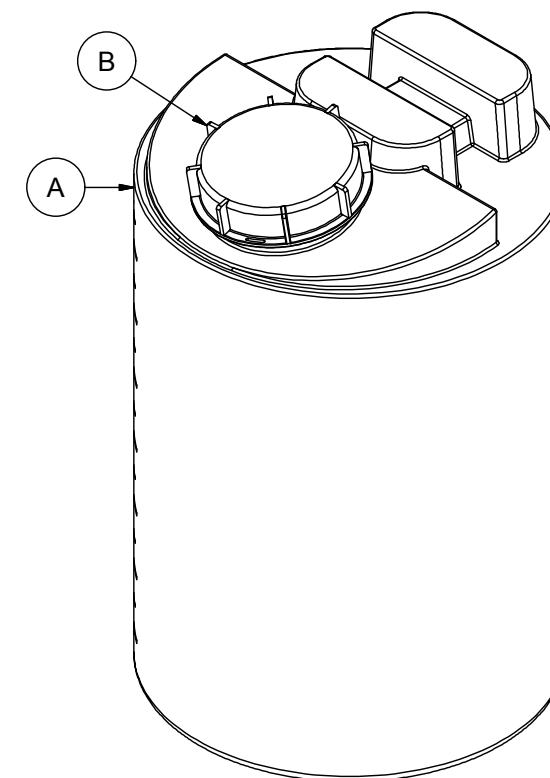
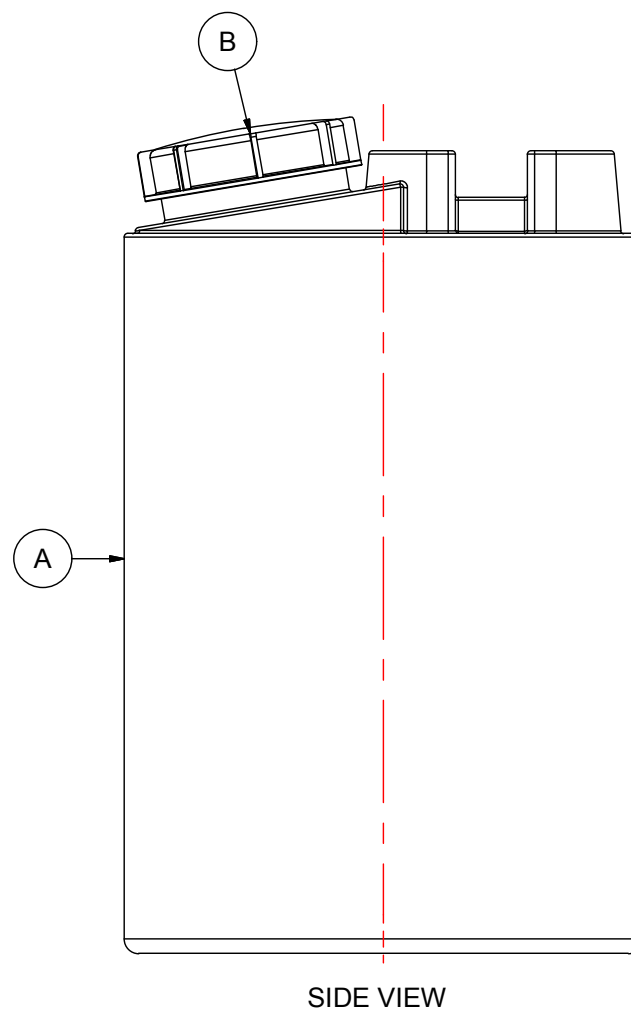
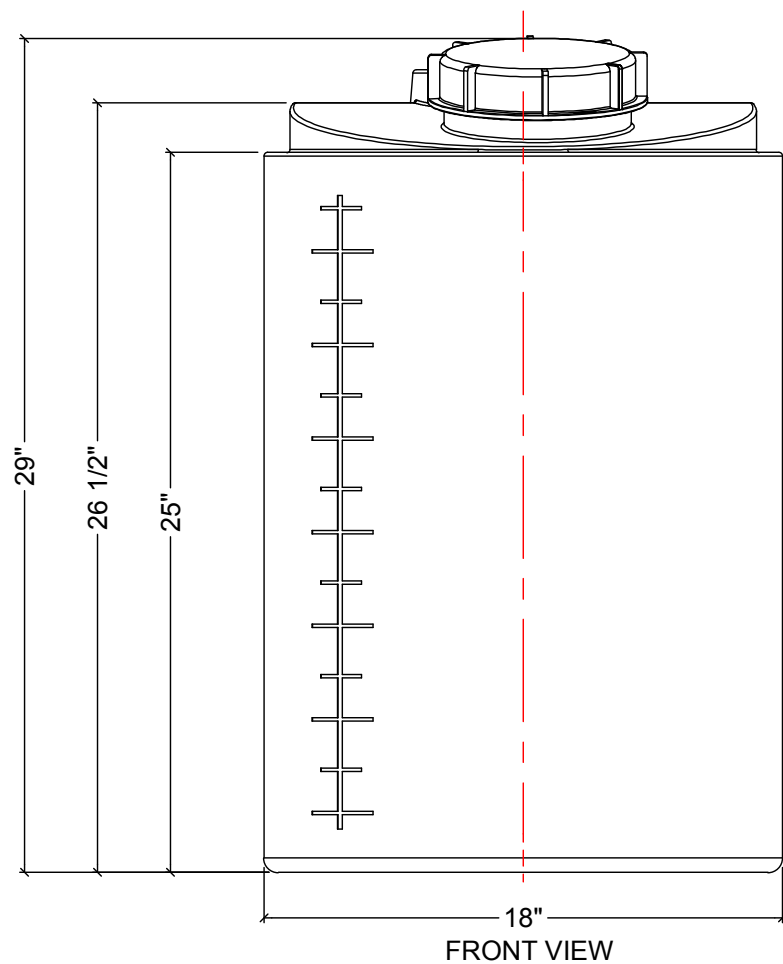

REV	DATE	DESCRIPTION	BY	APPD	REVD												
REVISIONS																	
CUSTOMER																	
TITLE		ACO JOB NO:															
100 L TOTE BARREL		PURCHASE ORDER NO:															
		PURCHASER'S EQUIP. NO:															
THIS DRAWING IS THE PROPERTY OF ROTOPLAST INC. AND SHALL NOT BE COPIED OR TRANSFERRED WITHOUT THE WRITTEN CONSENT OF ROTOPLAST INC.																	
ENGINEERS SEAL		<b>ACO CONTAINER SYSTEMS</b> DIVISION OF ROTOPLAST INC. <small>PICKERING - ONTARIO - CANADA</small>															
		<small>ACO CONTAINER SYSTEMS</small> <small>DIVISION OF ROTOPLAST INC.</small> <small>794 MCKAY RD.</small> <small>PICKERING, ONTARIO, CANADA</small> <small>TEL. 905-683-8222</small> <small>FAX 905-683-2969</small>		<table border="1"> <tr> <td>DESIGNED</td> <td></td> </tr> <tr> <td>DRAWN</td> <td>WM</td> </tr> <tr> <td>CHECKED</td> <td></td> </tr> <tr> <td>APPROVED</td> <td></td> </tr> <tr> <td>SCALE</td> <td>N.T.S.</td> </tr> <tr> <td>DATE</td> <td>15-03-16</td> </tr> </table>		DESIGNED		DRAWN	WM	CHECKED		APPROVED		SCALE	N.T.S.	DATE	15-03-16
DESIGNED																	
DRAWN	WM																
CHECKED																	
APPROVED																	
SCALE	N.T.S.																
DATE	15-03-16																
DWG No		PTB-100		REV 0													