

NOTES:

1. TANK IS MANUFACTURED TO ASTM-D-1998 STANDARD.
2. ALL DIMENSIONS ARE APPROXIMATE.

MATERIALS LIST		
ITEMS	DESCRIPTION	NOTES
A	CBO-750 TANK	
B	STEEL STAND FOR CBO-750	

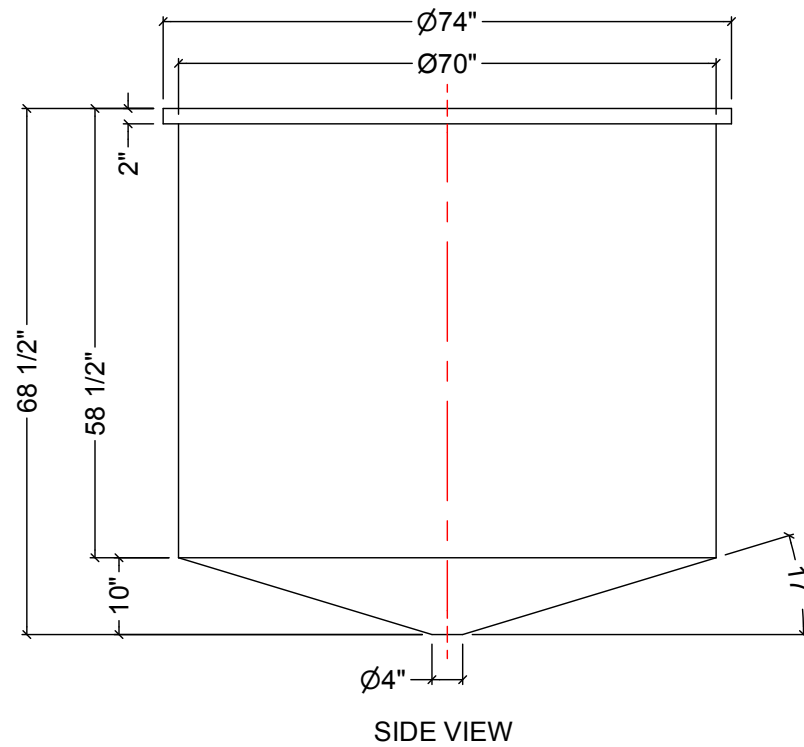
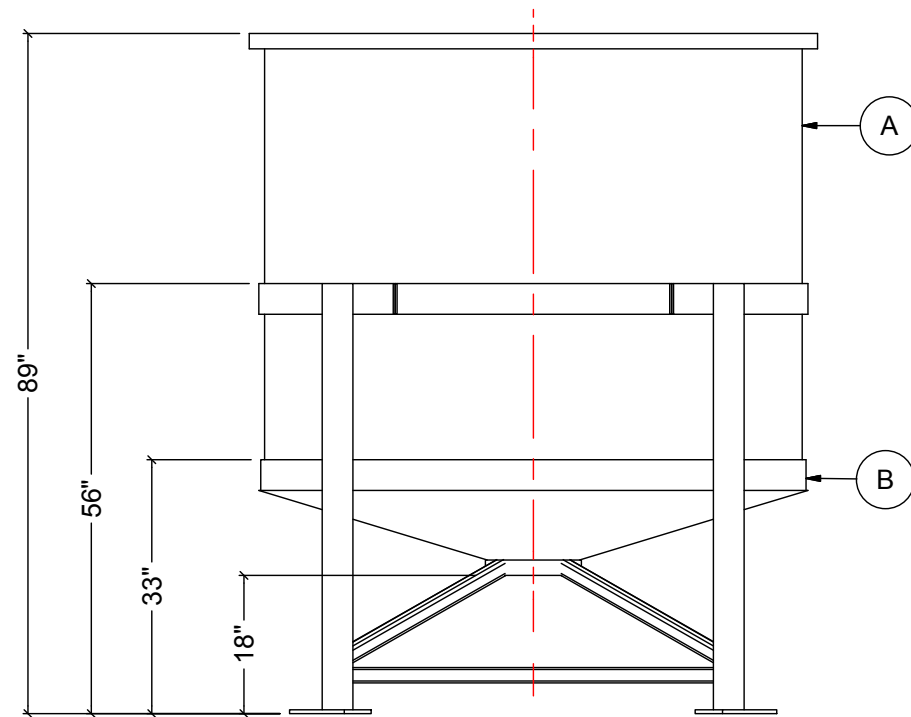
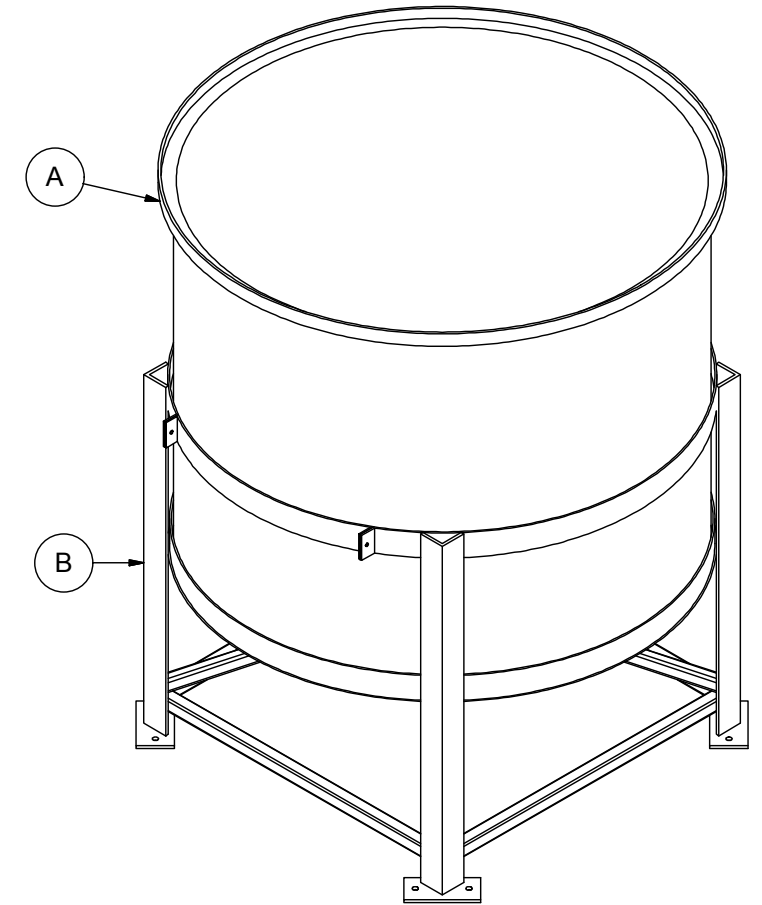

REV	DATE	DESCRIPTION	BY	APPD	REVD
REVISIONS					
CUSTOMER					
TITLE			ACO JOB NO:		
750 IG CONE BOTTOM			PURCHASE ORDER NO:		
OPEN TOP TANK			PURCHASER'S EQUIP. NO:		
THIS DRAWING IS THE PROPERTY OF ROTOPLAST INC. AND SHALL NOT BE COPIED OR TRANSFERRED WITHOUT THE WRITTEN CONSENT OF ROTOPLAST INC.					
ENGINEERS SEAL		ACO CONTAINER SYSTEMS DIVISION OF ROTOPLAST INC. <small>PICKERING - ONTARIO - CANADA</small> ACO CONTAINER SYSTEMS DIVISION OF ROTOPLAST INC. 794 MCKAY RD. PICKERING, ONTARIO, CANADA TEL. 905-683-8222 FAX 905-683-2969 DWG No			
		DESIGNED		DATE	
		DRAWN		29-03-16	
		CHECKED		N.T.S.	
		APPROVED		REV 0	
		SCALE		CBO-750	