

### MATERIALS LIST

ITEMS	DESCRIPTION	NOTES
A	IRD-90 SECONDARY CONTAINMENT BASIN	

**NOTES:**

1. TANK IS MANUFACTURED FROM HDPE.
2. TANK IS MANUFACTURED TO ASTM-D-1998 STANDARD.
3. TANK CAPACITY: 90 I.G. (430 L).
4. ALL DIMENSIONS ARE APPROXIMATE.

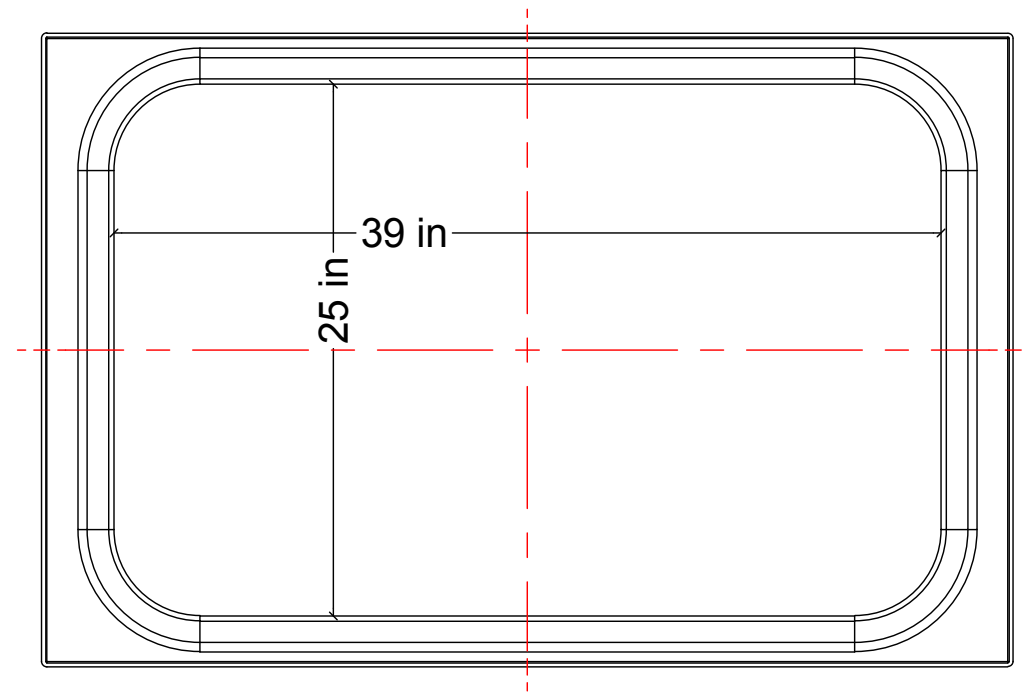

TOP VIEW

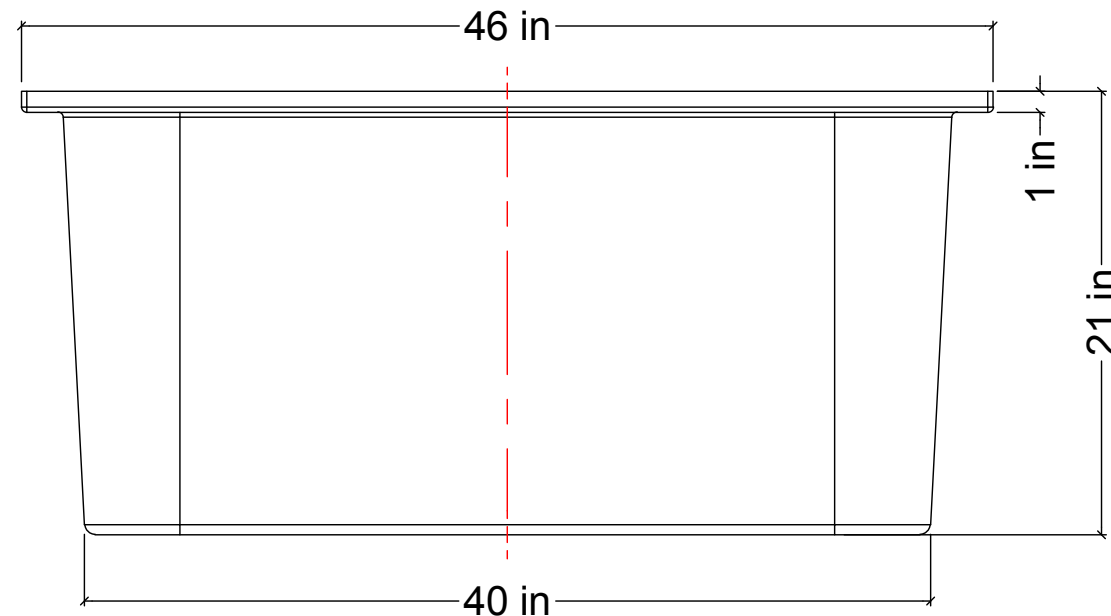
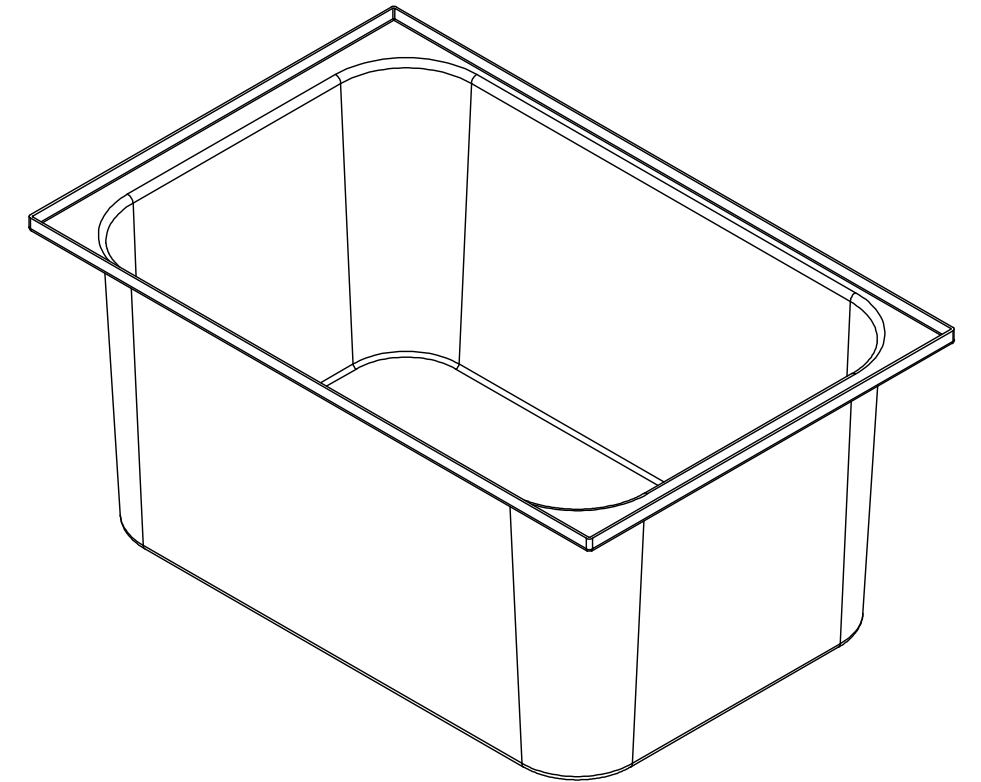

FRONT VIEW

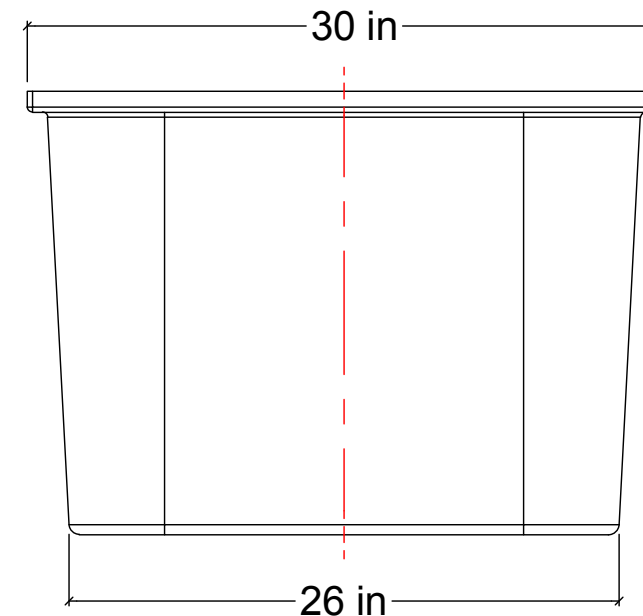

SIDE VIEW

REV	DATE	DESCRIPTION	BY	APPD	REVD
REVISIONS					
CUSTOMER					
TITLE		ACO JOB NO:			
90 IG SECONDARY CONTAINMENT BASIN		PURCHASE ORDER NO:			
		PURCHASER'S EQUIP. NO:			
THIS DRAWING IS THE PROPERTY OF ROTOPLAST INC. AND SHALL NOT BE COPIED OR TRANSFERRED WITHOUT THE WRITTEN CONSENT OF ROTOPLAST INC.					
ENGINEERS SEAL		<b>ACO CONTAINER SYSTEMS</b> DIVISION OF ROTOPLAST INC.			
<small>PICKERING - ONTARIO - CANADA</small>					
ACO CONTAINER SYSTEMS DIVISION OF ROTOPLAST INC. 794 MCKAY RD. PICKERING, ONTARIO, CANADA TEL. 905-683-8222 FAX 905-683-2969		DESIGNED			
		DRAWN			WM
		CHECKED			
		APPROVED			
		SCALE			N.T.S.
		DATE			15-03-16
DWG No		IRD-90			REV 0