

NOTES:

1. TANK IS MANUFACTURED TO ASTM-D-1998 STANDARD.
2. ALL DIMENSIONS ARE APPROXIMATE.

MATERIALS LIST		
ITEMS	DESCRIPTION	NOTES
A	RT-40 TANK	
B	5 1/2" THREADED LID	

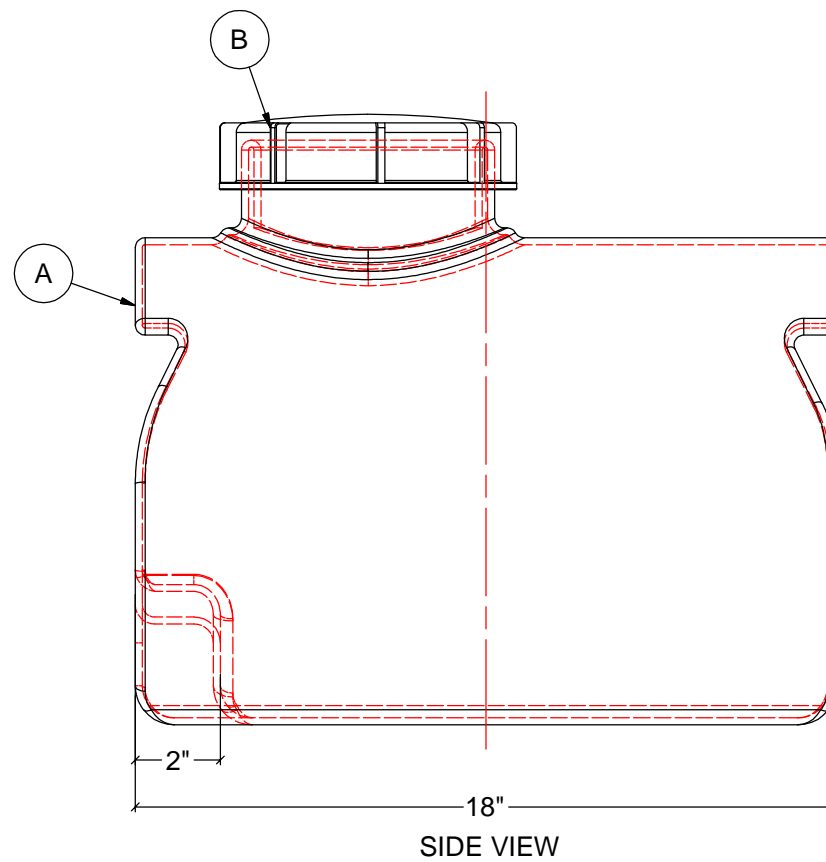
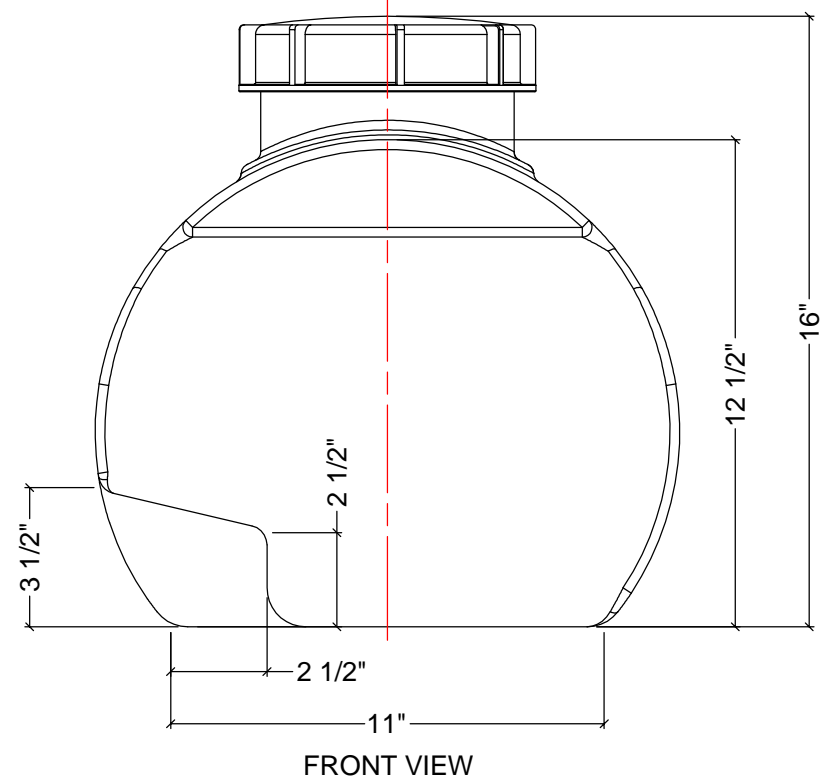
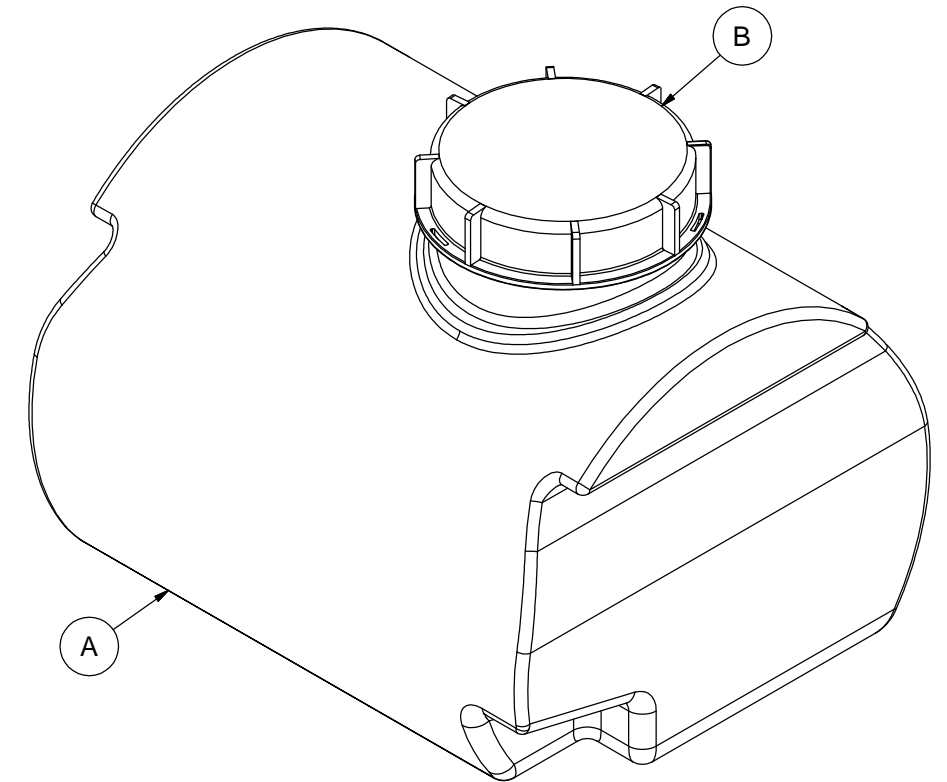

REV	DATE	DESCRIPTION	BY	APPD	REVD	
REVISIONS						
CUSTOMER						
TITLE			ACO JOB NO:			
40L ROUND TANK			PURCHASE ORDER NO:			
			PURCHASER'S EQUIP. NO:			
THIS DRAWING IS THE PROPERTY OF ACO CONTAINER SYSTEMS LTD. AND SHALL NOT BE COPIED OR TRANSFERRED WITHOUT THE WRITTEN CONSENT OF ACO CONTAINER SYSTEMS LTD.						
ENGINEERS SEAL		<b>ACO CONTAINER SYSTEMS LTD.</b>				
		<small>PICKERING - ONTARIO - CANADA</small>				
		<small>ACO CONTAINER SYSTEMS LTD.</small>		DESIGNED		
		<small>794 MCKAY RD.</small>		DRAWN	WM	
		<small>PICKERING, ONTARIO, CANADA</small>		CHECKED		
		<small>L1W 2Y4</small>		APPROVED		
		<small>TEL. 905-683-8222</small>		SCALE	N.T.S.	
		<small>FAX 905-683-2969</small>		DATE	15-03-10	
DWG No		RT-40			REV	0