

- NOTES:
1. CAPACITY: 270 IMP GAL (1230 L)
 2. TARE WEIGHT: 585 LBS (265 KG)
 3. PRIMARY MARKINGS: U.N. 31HA1/Y/

STACKING BRACKET DETAIL (H)

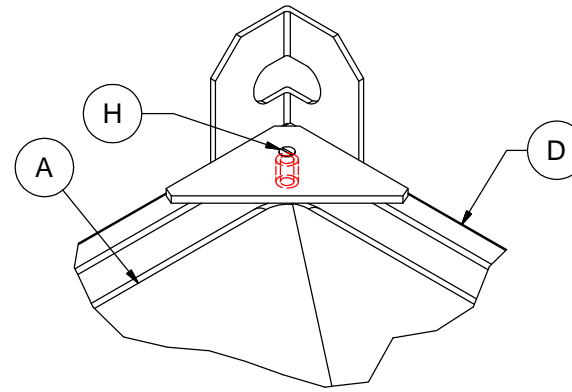

| MATERIALS LIST | | |
|----------------|--|----------------|
| ITEM | DESCRIPTION | NOTES |
| A | PTC-270 HDPE BOTTLE | |
| B | 6" ORANGE HDPE THREADED LID WITH GASKET (EPDM OR VITON) AND TIE DOWN | |
| C | 2" COMBI-VENT - VACUUM AND PRESSURE RELIEF (OPTIONAL) | IN LID |
| D | STEEL FRAME WITH 12" KICK PLATES AND VALVE PROTECTION GATE | |
| E | 2" BALL VALVE (POLYPRO OR STAINLESS STEEL) WITH GASKET (EPDM OR VITON) | FNPT OR CAMLOC |
| F | VALVE MOUNTING HARDWARE KIT | |
| G | BLACK POLY FRAME PILLOW | |
| H | FRAME CORNER STACKING BRACKET WITH SCREW | 4 PLACES |
| J | ALUMINUM U.N. FRAME TAG | |

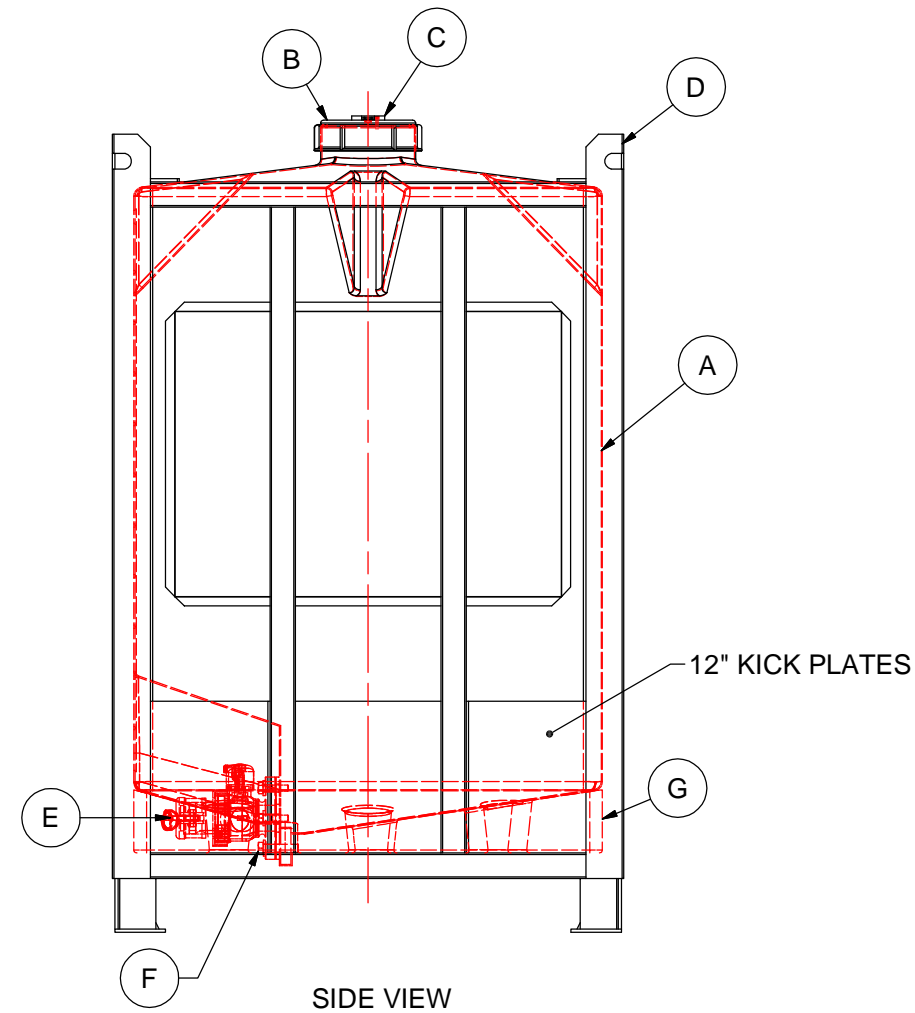
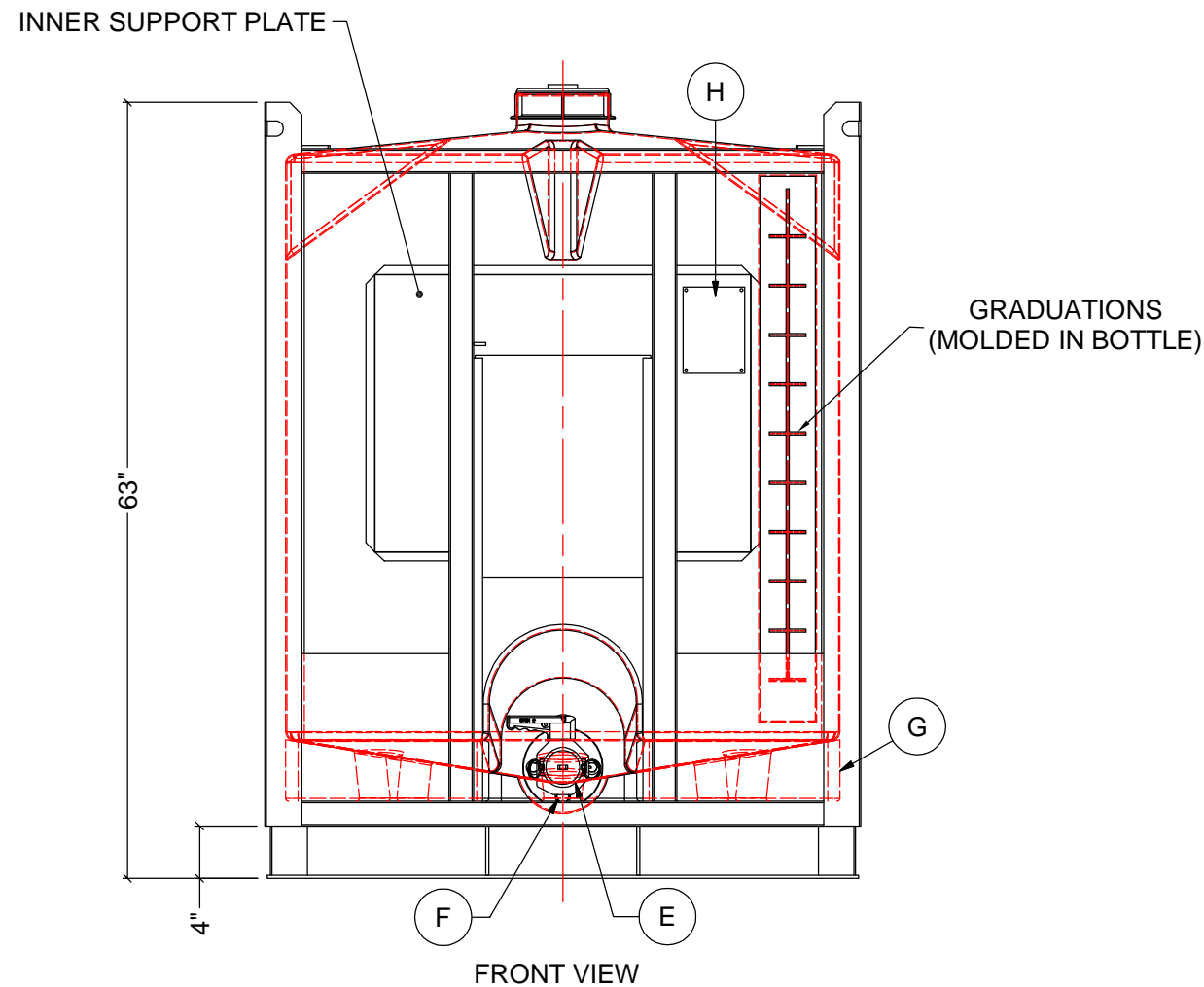
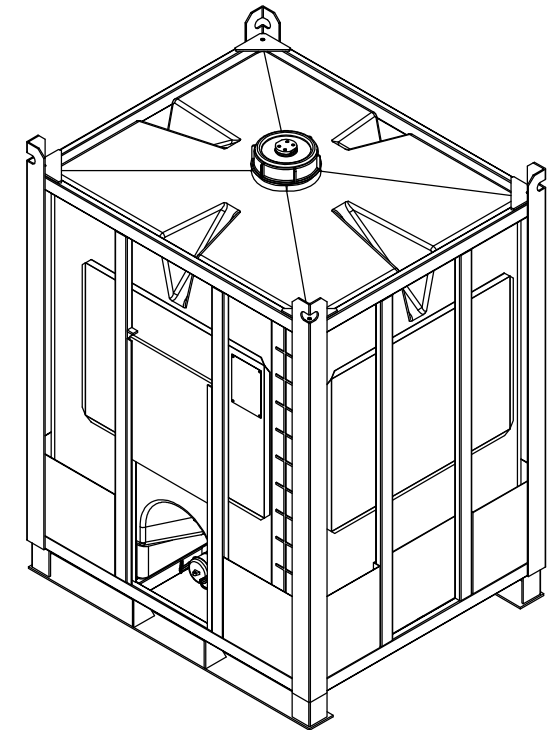

| REV | DATE | DESCRIPTION | BY | APPD | REVD |
|---|------|-------------|---|------|-----------------------------------|
| REVISIONS | | | | | |
| CUSTOMER | | | | | |
| TITLE PTC-270 WITH 12" KICK PLATES | | | ACO JOB NO: PURCHASE ORDER NO: PURCHASER'S EQUIP. NO: | | |
| THIS DRAWING IS THE PROPERTY OF ACO CONTAINER SYSTEMS LTD. AND SHALL NOT BE COPIED OR TRANSFERRED WITHOUT THE WRITTEN CONSENT OF ACO CONTAINER SYSTEMS LTD. | | | | | |
| ENGINEERS SEAL | | | ACO CONTAINER SYSTEMS LTD. <small>PICKERING - ONTARIO - CANADA</small> ACO CONTAINER SYSTEMS LTD. 794 MCKAY RD. PICKERING, ONTARIO, CANADA L1W 2Y4 TEL. 905-683-8222 FAX 905-683-2969 DWG No | | |
| | | | DESIGNED DRAWN CHECKED APPROVED SCALE DATE | | WM N.T.S. 22-10-09 REV 0 |
| | | | PTC-270 | | |