

PLAN VIEW

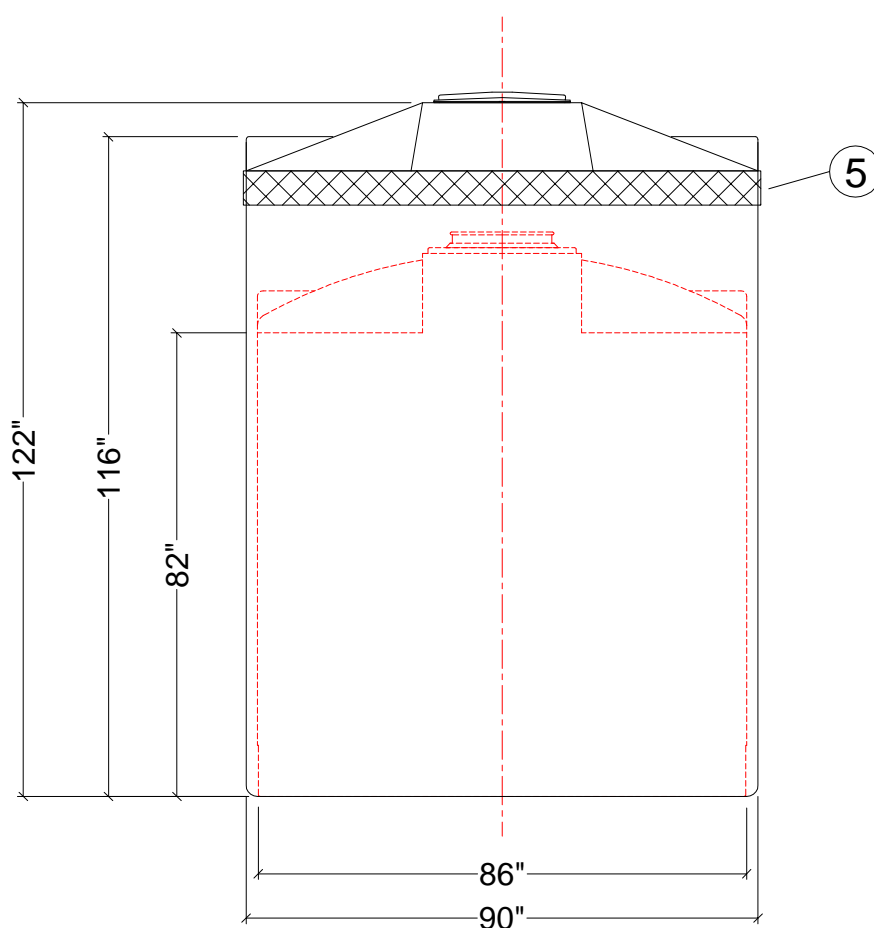

FRONT VIEW

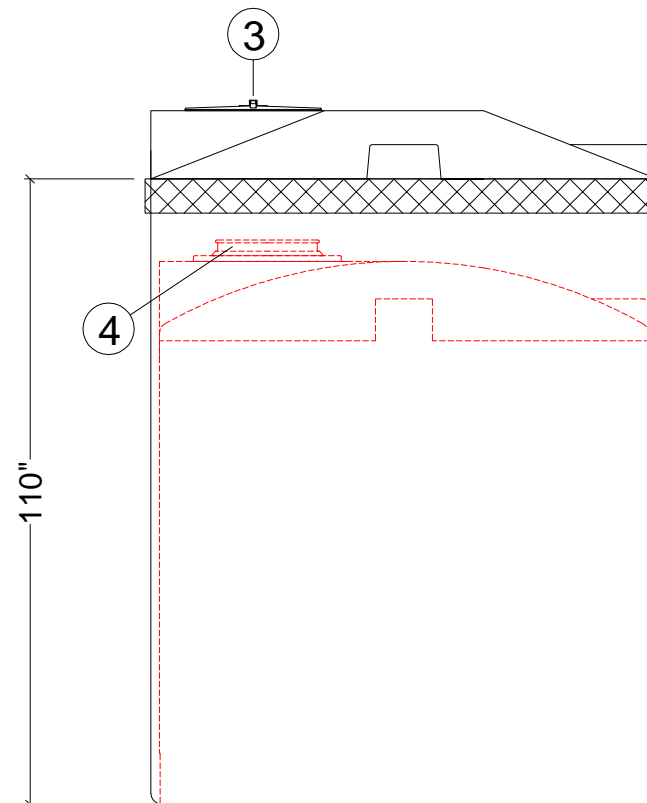

SIDE VIEW

NOZZLE SCHEDULE

ITEM	SIZE	DESCRIPTION	NOTES

NOTES:

1. TANK IS MANUFACTURED TO ASTM-D-1998 STANDARD.
2. 21" THREADED LID. (OUTSIDE TANK)
3. 14" LID WITH GASKET AND LOCK RING. (INSIDE TANK)
4. HDPE WELDED BAND.

REV	DATE	DESCRIPTION	BY	APPD	REVD
REVISIONS					

CUSTOMER	
TITLE	ACO JOB NO:
1650 I.G. (7300L)	-
DOUBLE WALL TANK	PURCHASE ORDER NO:
	-
	PURCHASER'S EQUIP. NO:
	-

THIS DRAWING IS THE PROPERTY OF ACO CONTAINER SYSTEMS LTD. AND SHALL NOT BE COPIED OR TRANSFERRED WITHOUT THE WRITTEN CONSENT OF ACO CONTAINER SYSTEMS LTD.

ENGINEERS SEAL	ACO CONTAINER SYSTEMS LTD.	
	<small>PICKERING - ONTARIO - CANADA</small>	
	ACO CONTAINER SYSTEMS LTD.	DESIGNED
	794 MCKAY RD.	DRAWN
	PICKERING, ONTARIO, CANADA	CHECKED
	L1W 2Y4	APPROVED
	TEL. 905-683-8222	SCALE
	FAX 905-683-2969	DATE
		N.T.S.
		04-30-08
DWG No	DWE-1650	REV
		0