

PLAN VIEW

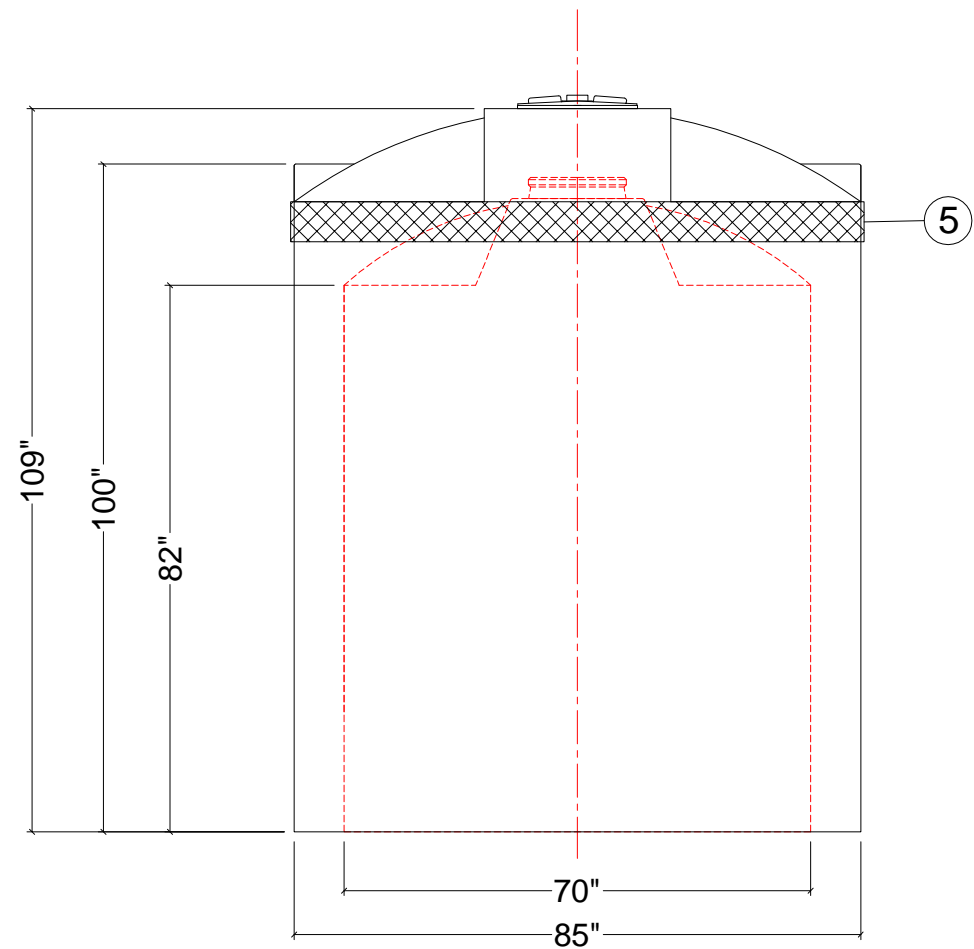

FRONT VIEW

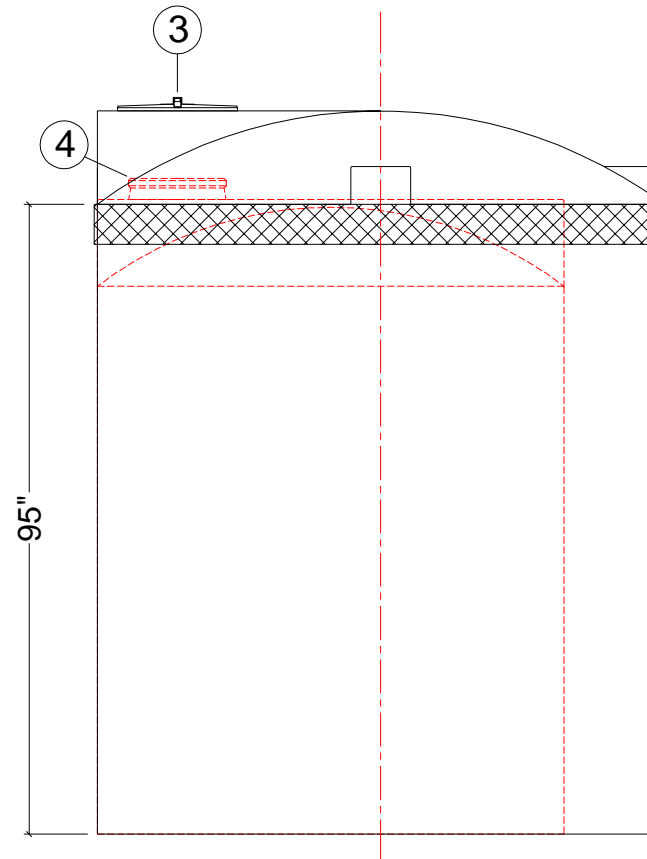

SIDE VIEW

NOZZLE SCHEDULE			
ITEM	SIZE	DESCRIPTION	NOTES

NOTES:

1. TANK IS MANUFACTURED TO ASTM-D-1998 STANDARD.
2. 15" THREADED LID. (OUTSIDE TANK)
3. 14" LID WITH GASKET AND LOCK RING. (INSIDE TANK)
4. HDPE WELDED BAND.

REV	DATE	DESCRIPTION	BY	APPD	REVD
REVISIONS					
CUSTOMER					
TITLE		ACO JOB NO:		-	
1250 I.G. (5700L)		PURCHASE ORDER NO:		-	
DOUBLE WALL TANK		PURCHASER'S EQUIP. NO:		-	
THIS DRAWING IS THE PROPERTY OF ACO CONTAINER SYSTEMS LTD. AND SHALL NOT BE COPIED OR TRANSFERRED WITHOUT THE WRITTEN CONSENT OF ACO CONTAINER SYSTEMS LTD.					
ENGINEERS SEAL		ACO CONTAINER SYSTEMS LTD.			
<small>PICKERING - ONTARIO - CANADA</small>					
ACO CONTAINER SYSTEMS LTD.		DESIGNED	-		
794 MCKAY RD.		DRAWN	W.M.		
PICKERING, ONTARIO, CANADA		CHECKED			
L1W 2Y4		APPROVED			
TEL. 905-683-8222		SCALE	N.T.S.		
FAX 905-683-2969		DATE	04-29-08		
DWG No		DWE-1250		REV	0