

TOP VIEW

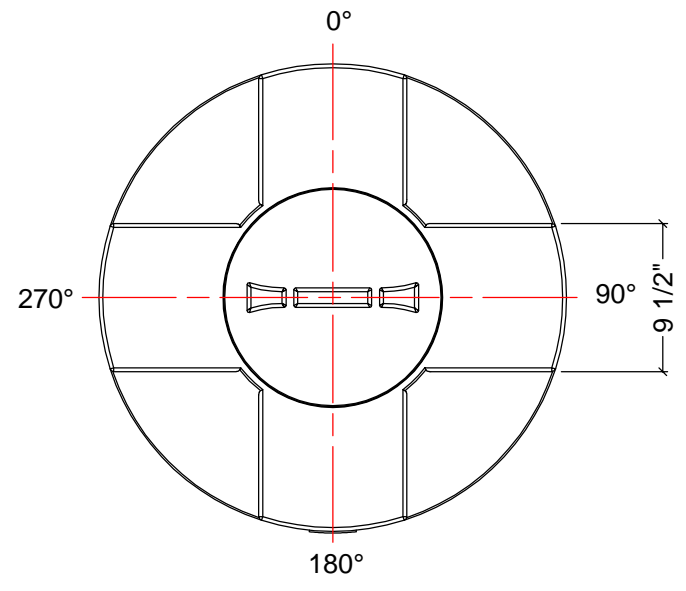

NOTES:

- 1. TANK IS MANUFACTURED TO ASTM-D-1998 STANDARD.
- 2. ALL DIMENSIONS ARE APPROXIMATE.

MATERIALS LIST		
ITEMS	DESCRIPTION	NOTES
A	CT-150-CH TANK	
B	12" THREADED MCPHEE LID	

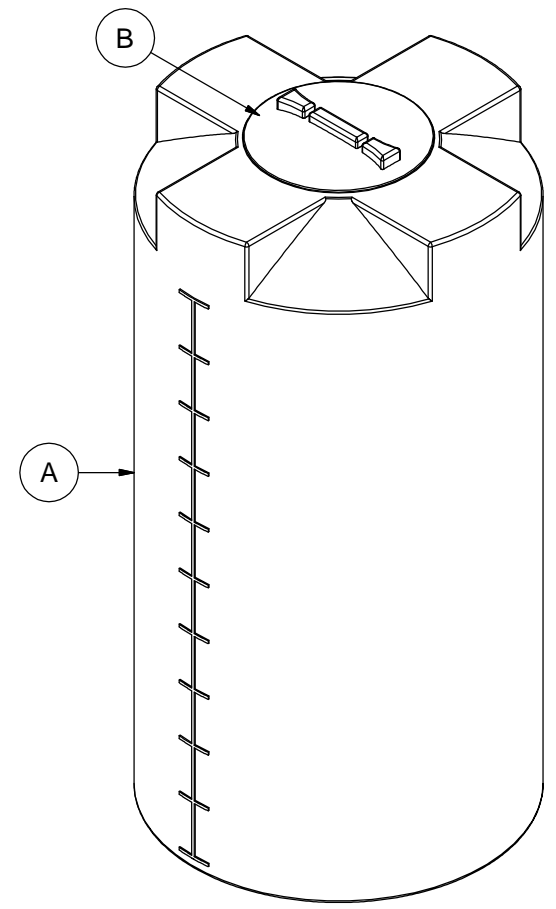
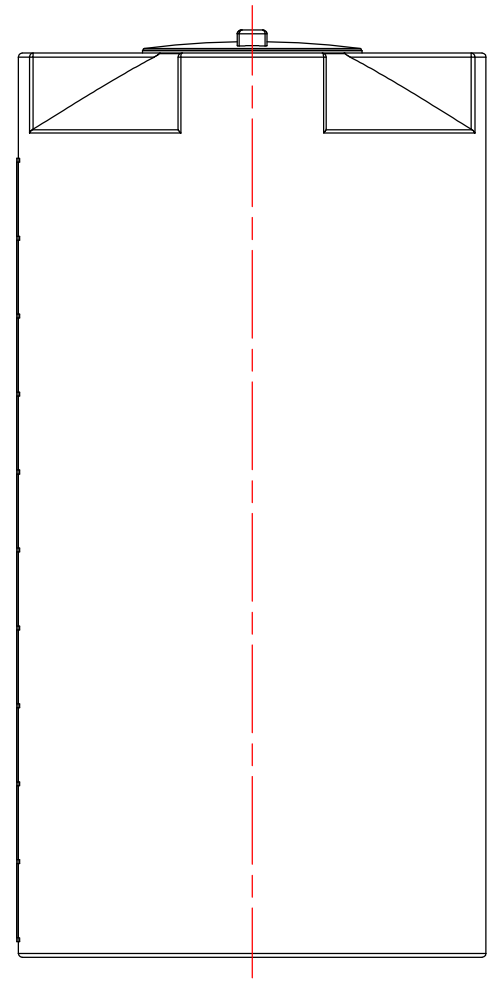
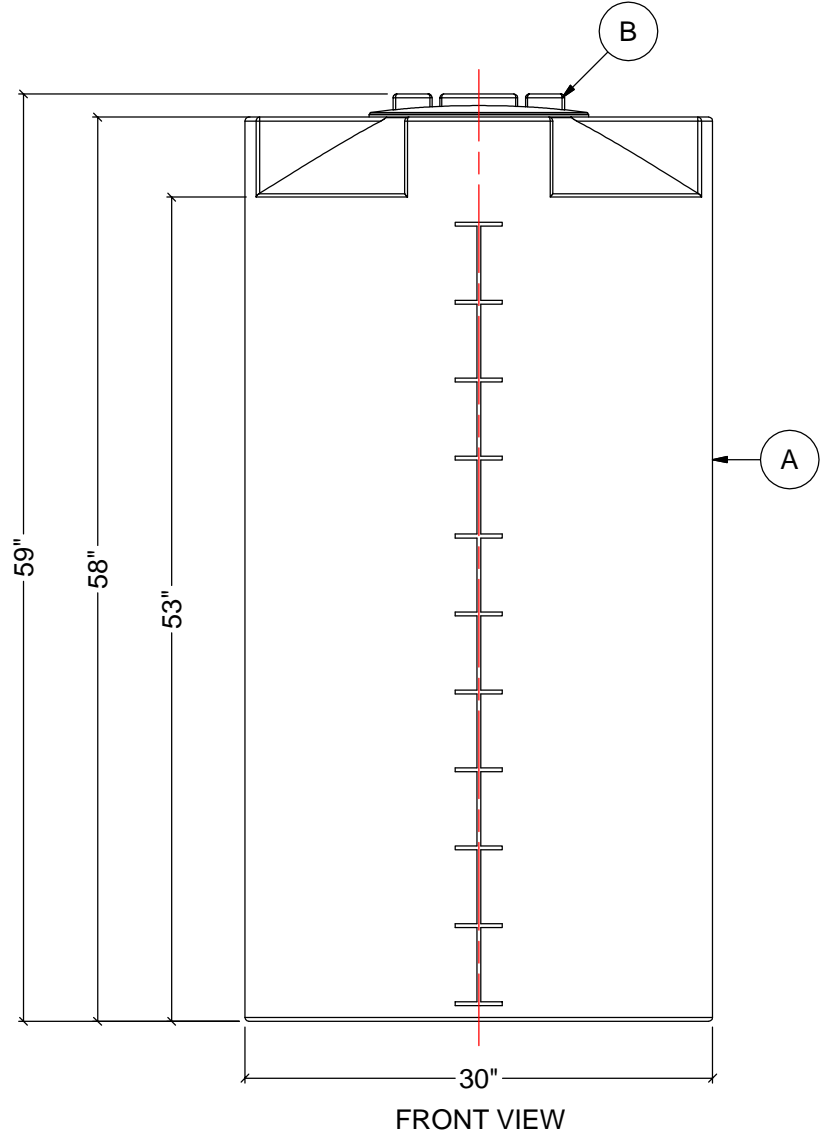

SIDE VIEW

FRONT VIEW

REV	DATE	DESCRIPTION	BY	APPD	REVD
REVISIONS					

CUSTOMER

TITLE: 150 I.G. CLOSED TOP TANK

ACO JOB NO:

PURCHASE ORDER NO:

PURCHASER'S EQUIP. NO:

THIS DRAWING IS THE PROPERTY OF ACO CONTAINER SYSTEMS LTD. AND SHALL NOT BE COPIED OR TRANSFERRED WITHOUT THE WRITTEN CONSENT OF ACO CONTAINER SYSTEMS LTD.

ENGINEERS SEAL	<b>ACO CONTAINER SYSTEMS LTD.</b>	
	<small>PICKERING - ONTARIO - CANADA</small>	
	ACO CONTAINER SYSTEMS LTD. 794 MCKAY RD. PICKERING, ONTARIO, CANADA L1W 2Y4 TEL. 905-683-8222 FAX 905-683-2969	DESIGNED DRAWN CHECKED APPROVED SCALE DATE
	DWG No	CT-150-CH
		WM N.T.S. 12-05-09 REV 0